

**INTERNATIONAL  
CADET  
CLASS RULES**

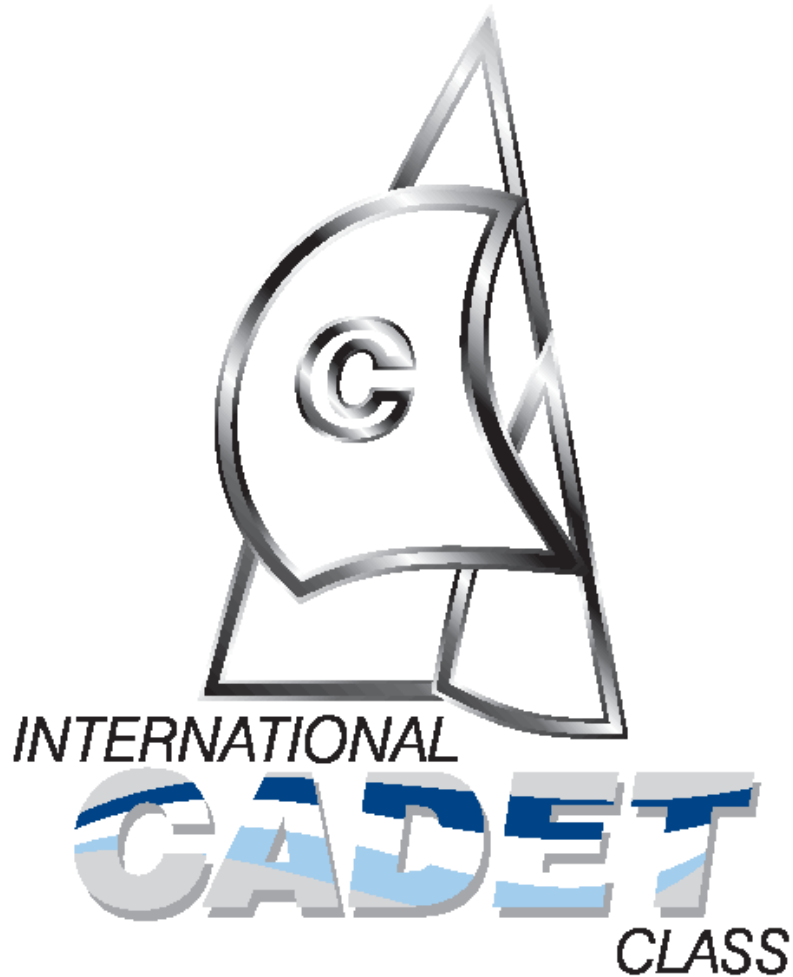

**1<sup>st</sup> December 2011**



The Cadet was designed in 1946 by Jack Holt and was adopted as an international class in 1958.

# INDEX

---

## PART I – ADMINISTRATION

### Section A – General

A.1	Language .....	4
A.2	Abbreviations .....	4
A.3	Authorities.....	4
A.4	Administration of the Class .....	4
A.5	ISAF Rules .....	4
A.6	Class Rules Variations .....	4
A.7	Class Rules Amendments .....	4
A.8	Class Rules Interpretation .....	4
A.9	International Class Fee and ISAF Building Plaque .....	5
A.10	Sail Numbers .....	5
A.11	Hull Certification .....	5
A.12	Initial Hull Certification .....	5
A.13	Validity of Certificate .....	5
A.14	Hull Re-Certification .....	6
A.15	Retention of Certification Documentation .....	6

### Section B – Boat Eligibility

B.1	Class Rules and Certification .....	6
B.2	Flotation Checks .....	6
B.3	Class Association Markings .....	6

## PART II – REQUIREMENTS AND LIMITATIONS

### Section C – Conditions for Racing

C.1	General .....	7
C.2	Crew .....	7
C.3	Personal Equipment .....	7
C.4	Advertising .....	7
C.5	Portable Equipment .....	7
C.6	Boat .....	8
C.7	Hull .....	8
C.8	Hull Appendages.....	8
C.9	Rig .....	9
C.10	Sails .....	10

### Section D– Hull

D.1	General .....	11
D.2	Decks and Bulkheads .....	14
D.3	Buoyancy Tanks .....	15

D.4	Gunwale Rubbing Beads .....	15
D.5	Keel, Skeg, and Daggerboard Case ....	16
D.6	Rubbing Bands.....	17
D.7	Thwart .....	17
D.8	Splash or Spray Guards .....	17
D.9	Fittings.....	18
D.10	Weight, Correctors and C of G .....	20

### Section E – Hull Appendages

E.1	Parts .....	21
E.2	General .....	21
E.3	Daggerboard .....	21
E.4	Rudder Blade, Rudder Stock and Tiller .....	22

### Section F – Rig

F.1	Parts .....	23
F.2	General .....	23
F.3	Mast .....	23
F.4	Boom .....	24
F.5	Spinnaker Pole .....	25
F.6	Standing Rigging .....	25
F.7	Running Rigging .....	26

### Section G – Sails

G.1	Parts .....	27
G.2	General .....	27
G.3	Mainsail .....	27
G.4	Headsail .....	28
G.5	Spinnaker .....	29

## PART III – APPENDICES

H.1	Wooden Boat Supplement .....	30
H.2	Measurement Plan No.1.....	32
H.3	Measurement Plan No.2.....	33
H.4	Measurement Plan No.3.....	34
H.5	Measurement Plan No.4.....	35
H.6	Measurement Plan No.5.....	36
H.7	Measurement Plan No.6.....	37
H.8	Buoyancy Tests.....	38
H.9	Examples Relating to Minor Repairs...	38

# INTRODUCTION

---

*The International Cadet Class is a Closed Class Rule (formerly called a One-Design) dinghy for a crew of two junior sailors. The intention of the rules is that the boats shall be as alike as possible in all respects affecting speed and ease of handling.*

*International Cadet hulls, hull appendages, rigs and sails are measurement controlled.*

*International Cadet hulls in GRP shall only be manufactured by licensed manufacturers as approved and listed from time to time by the ICCA – in the class rules referred to as licensed manufacturers.*

*International Cadet hulls in wood, hull appendages, rigs and sails may be manufactured by optional builders and suppliers.*

*Owners and crews should be aware that compliance with rules in Sections C, E and F are NOT checked as part of the certification process. This means that even when these items are new their compliance with these rules should be checked by the owner.*

*The onus at all times is on the owner and the **crew** to ensure that their **boat** complies with these rules. The existence of a measurement **certificate** is not guarantee that the **boat** complies with these rules.*

*Rules regulating the use of equipment during a race are contained in Section C of these class rules, in ERS Part I and in the Racing Rules of Sailing.*

*This introduction only provides an informal background and the International Cadet Class Rules proper begin on the next page.*

**PLEASE REMEMBER-**  
**IF THESE RULES DO NOT SAY YOU CAN,**  
**THEN YOU CAN NOT!**

# PART I – ADMINISTRATION

---

## Section A – General

### A.1 LANGUAGE

- A.1.1 The official language of the class is English and in case of dispute over translation the English text shall prevail.
- A.1.2 The word “shall” is mandatory and the word “may” is permissive.

### A.2 ABBREVIATIONS

- A.2.1 ISAF International Sailing Federation  
MNA ISAF Member National Authority  
ICA International Cadet Class Association  
NCA National Class Association  
ERS Equipment Rules of Sailing  
RRS Racing Rules of Sailing  
IHC In House Certification

### A.3 AUTHORITIES

- A.3.1 The international authority of the class is the ISAF which shall co-operate with the ICA in all matters concerning these **class rules**.
- A.3.2 Notwithstanding anything contained herein, the **certification authority** has authority to withdraw a **certificate** and shall do so on the request of the ISAF or ICA.

### A.4 ADMINISTRATION OF THE CLASS

- A.4.1 ISAF has delegated its administrative functions of the class to MNAs. The MNA may delegate part or all of its functions, as stated in these **class rules**, to an NCA.
- A.4.2 In countries where there is no MNA, or the MNA does not wish to administer the class, its administrative functions as stated in these **class rules** shall be carried out by the ICA which may delegate the administration to an NCA.
- A.4.3 The ISAF or an MNA may appoint one or more **In-House Official Measurers** to measure and **certify sails** produced by a manufacturer.
- A.4.4 **Certification** Control shall be carried out by a measurer recognised for the class by a MNA or an NCA who shall complete the appropriate documentation and sign measurement forms or **certificates** except that **sails** may also be measured and certified by an **In-House Official Measurer**. Some measurers may only be recognised for some part or parts of a **boat**.

### A.5 ISAF RULES

- A.5.1 These **class rules** shall be read in conjunction with the ERS.
- A.5.2 Except where used in headings, when a term is printed in “**bold**” the definition in the ERS applies and when a term is printed in “*italics*” the definition in the RRS applies.

### A.6 CLASS RULES VARIATIONS

- A.6.1 These **class rules** shall not be varied by the *notice of race* or by the *sailing instructions* except as provided by A.6.2.
- A.6.2 At World, Continental or Regional Championships the *notice of race* or the *sailing instructions* may vary these **class rules** only with the agreement of the ICA and ISAF.
- A.6.3 No modifications or additional fittings are allowed without the written approval of the ISAF or the ICA.

### A.7 CLASS RULES AMENDMENTS

- A.7.1 Amendments to these **class rules** shall be proposed by the ICA and are subject to the approval of the ISAF in accordance with the ISAF Regulations.

### A.8 CLASS RULES INTERPRETATION

- A.8.1 Interpretation of these **class rules**, except as provided by A.8.2, shall be made in accordance with the ISAF Regulations.

- A.8.2 Any interpretation of these **class rules** which is required at an event at which an International Jury constituted in accordance with the RRS is officiating shall be made only by the International Jury. Such interpretation shall only be valid during the event, and shall not depart from any pre-existing interpretation under A.8.1 which is current and binding at the start of the event. Such interpretation shall only be valid during the event and the *organising authority* shall, as soon as practical after the event, inform the ISAF, the MNA and the ICA of such interpretation.

#### **A.9 INTERNATIONAL CLASS FEE AND ISAF BUILDING PLAQUE**

- A.9.1 Each new **hull** shall have a sail number and ISAF plaque.
- A.9.2 The ICA shall obtain ISAF plaques from ISAF.
- A.9.3 The ICA shall, on payment to it of the fee required from time to time, issue sail numbers and ISAF plaques to MNAs or NCAs as may be required for allocation in their countries.
- A.9.4 The builder or owner of each new **hull** shall request a sail number and ISAF plaque from his MNA or NCA as appropriate (or, if none, or if the ICA so permits, directly from the ICA).
- A.9.5 The MNAs and NCAs shall, on payment by the builder or owner of the fee required from time to time, (i) issue an ISAF plaque and a sail number out of those issued to them by the ICA; and (ii) register details of the hull, its builder and owner.
- A.9.6 Replacement ISAF plaques (“R” plaques) are also available from the ICA.

#### **A.10 SAIL NUMBERS**

- A.10.1 The sail number for a boat will be the number issued for its **hull** which will be its ISAF plaque number (except where an “R” plaque has been issued and except where a **boat** is not required to carry a plaque).

#### **A.11 HULL CERTIFICATION**

- A.11.1 A **certificate** shall record the following information:
- (a) Class
  - (b) **Certification authority**
  - (c) Whether **hull** is Mark I, II, III or IV.
  - (d) Sail number
  - (e) Owner
  - (f) EU Craft Identification Number - CIN (where applicable)
  - (g) Builder/Manufacturers details
  - (h) Date of initial fundamental measurement.
  - (i) Date of issue of initial **certificate**.
  - (j) If a **hull** is re-measured and re-certified, the date of such re-measurement and re-certification.
  - (k) Date of issue of **certificate**.
  - (l) Corrector weight details.
  - (m) Buoyancy endorsement.

#### **A.12 INITIAL HULL CERTIFICATION**

- A.12.1 For a **certificate** to be issued in respect of a **hull** not previously **certified**:
- (a) **Certification control** shall be carried out by a measurer who shall complete the appropriate measurement form.
  - (b) The measurement form and **certification** fee, if required, shall be sent to the **certification authority**.
  - (c) The measurer shall report on the measurement form anything which he considers to be a departure from the intended nature and design of the **boat**, or to be against the general interest of the class. The **certification authority** shall pass the report to the ICA. At the request of the ISAF or the ICA the **certification authority** shall not issue or shall withdraw a **certificate** for such a **boat**, even if the specific requirements of the rules are satisfied.
  - (d) Upon receipt of a satisfactorily completed measurement form and **certification** fee, if required, the **certification authority** may issue a **certificate**.

#### **A.13 VALIDITY OF CERTIFICATE**

- A.13.1 A **hull certificate** becomes invalid upon:
- (a) The change to any items recorded on the hull **certificate** as required under A.11.

- (b) The expiration of a valid buoyancy endorsement unless and until a further valid buoyancy endorsement is in place.
- (c) withdrawal by the **certification authority**.
- (d) the issue of a new **certificate**.
- (e) Any alteration to the **corrector weights** of the **hull** unless and until re-weighed by a measurer and an endorsement of the details has been made by him on the **certificate**.
- (f) Any alteration or repair to items required to be measured by the measurement form in force at the time of the alteration or repair, other than permitted routine maintenance or Permitted Repairs (as defined below)

All **boats** shall be subject to re-measurement at the discretion of the ICA, NCA or *race committee*.

#### **A.14 HULL RE-CERTIFICATION**

A.14.1 When a **certificate** is invalidated under A.13.1(f), the **hull** shall be re-measured by a measurer and the details entered on a new measurement form.

A.14.2 The **certification authority** may issue a **certificate** in respect of a previously certified **hull**:

- (a) when it is invalidated under A.13.1 (a), after receipt of the old **certificate**, and **certification** fee if required.
- (b) when it is invalidated under A.13.1 (c), at its discretion, after receipt of the **certification** fee if required and, in a case where the withdrawal of the **certificate** was at the request of the ISAF or ICA subject to the approval of the body which made the request.
- (c) when it is invalidated under A.13.1(f), after receipt of the old **certificate**, and **certification** fee if required, an appropriately completed measurement form and proof of a successful annual buoyancy test completed by a measurer or Squadron Captain.
- (d) when a new **certificate** is required for administrative or other reasons, after receipt of the **certification** fee if required and, if required by the **certification authority** in the circumstances of the case, after receipt of the old **certificate**.

#### **A.15 RETENTION OF CERTIFICATION DOCUMENTATION**

A.15.1 The **certification authority** shall:

- (a) retain the original documentation upon which the current **certificate** is based.
- (b) upon request, transfer this documentation to the new **certification authority** if the hull is exported.
- (c) upon initial **hull certification** and after a **hull** has been re-measured in accordance with A.14.1 the **certification authority** shall send to the ICA copies, preferably in electronic format (for example pdf copies) attached to an e-mail, of the original documentation (including the measurement form) on which the **certificate** issued or re-issued by it is based.

## **Section B – Boat Eligibility**

For a **boat** to be eligible for *rac*ing, it shall comply with the rules in this section.

### **B.1 CLASS RULES AND CERTIFICATION**

B.1.1 The **boat** shall:

- (a) be in compliance with the **class rules**.
- (b) have a valid **hull certificate**.
- (c) have valid **certification marks** as required
- (d) have as its owner a person who is a current member of an NCA or, when there is no NCA in his nation, of the MNA.
- (f) have an ISAF plaque for World Championships regardless of the age of the **boat**. In order for a **boat** to be eligible for a World Championships which was subject to initial fundamental measurement before the ISAF plaque requirement was introduced, it shall carry an “R” plaque.

### **B.2 FLOTATION CHECKS**

B.2.1 The **certificate** shall carry a dated buoyancy endorsement indicating satisfactory compliance with the relevant test specified in H.8.

B.2.2 A buoyancy endorsement shall remain valid only for a period of 12 months from the date of the test to which it relates.

### **B.3 CLASS ASSOCIATION MARKINGS**

- B.3.1 A valid National Class Association or Authority Sticker or card, if required by the NCA or MNA shall be affixed to the **certificate**.

## **PART II – REQUIREMENTS AND LIMITATIONS**

The **crew** and the **boat** shall comply with the rules in Part II when *racing*. In case of conflict Section C shall prevail.

The rules in Part II are **closed class rules**. **Certification control** and **equipment inspection** shall be carried out in accordance with the ERS except where varied in this Part.

Such fastenings, glues, backing plates, pads and ropes are permitted as may be appropriate in order to attach permitted fittings or equipment, but shall not serve any other purpose.

## **Section C – Conditions for Racing**

### **C.1 GENERAL**

- C.1.1 The ERS Part I - Use of Equipment - shall apply.  
C.1.2 The function of permitted fittings shall not be added to.

### **C.2 CREW**

#### **C.2.1 LIMITATIONS**

- (a) The **crew** shall consist of 2 persons.  
(b) Age. The maximum age is seventeen years on December 31<sup>st</sup> of the year of the scheduled first race of an event.

### **C.3 PERSONAL EQUIPMENT**

#### **C.3.1 MANDATORY**

- (a) The **boat** shall be equipped with effective personal buoyancy for each crew member.  
(b) The **crew** shall wear the personal buoyancy properly secured outside all clothing except that, where the personal buoyancy is non-inflatable, a close fitting, sleeveless, pocketless bib or vest may be worn outside the personal buoyancy.

### **C.4 ADVERTISING**

#### **C.4.1 LIMITATIONS**

Advertising shall only be displayed in accordance with the ISAF Advertising Code.

### **C.5 PORTABLE EQUIPMENT**

#### **C.5.1 FOR USE**

##### **(a) MANDATORY**

- (1) Mark I and II versions shall carry a bucket of minimum 5 litres capacity, tied to the boat except when in use.

##### **(b) OPTIONAL**

- (1) Electronic or mechanical timing devices.  
(2) Hand bailers, buckets and sponges.  
(3) Flag, burgee, or mechanical wind direction indicator.  
(4) Anchor and anchor warp.  
(5) Personal effects such as bags, bottles, food containers and writing equipment.  
(6) One compass. If a compass is carried as portable equipment no other compass can be carried or fixed to the **hull** or **mast**, so that no more than one compass shall be on board the **boat** (whether it is fixed or portable)  
(7) Any electronic compass used shall not have any functions other than heading and timing functions and shall not deliver, store or correlate information in any way except as described here:

- (i) The display letters and numerals shall be not more than 30 mm high.
- (ii) The display shall only be capable of showing the following:
  - heading (damping may be adjusted manually),
  - heading  $\pm$  a tacking angle (which may be adjusted manually),
  - time,
  - race timing information,
  - identification,
  - battery condition, system error, adjustment and calibration information.
- (iii) Race timing information may be transmitted by sound.

C.5.2 NOT FOR USE

(a) MANDATORY

- (1) A painter which shall float and be of minimum diameter 6mm and minimum length 5 m shall be attached to the bow ring.
- (2) One paddle properly secured to the boat.

(b) OPTIONAL

- (1) Spare parts such as blocks, ropes, shackles etc.

C.6 BOAT

C.6.1 FLOTATION AND BUOYANCY TEST

Whenever afloat the **boat** shall be capable of passing the test described in rule H.8.1.

C.7 HULL

C.7.1 FITTINGS

- (a) Hatch covers and drainage plugs shall be securely fastened.

C.7.2 MODIFICATIONS, MAINTENANCE AND REPAIR

- (a) The **hull** shall not be altered in any way except as permitted by these **class rules** (see D.1.3 and D.1.4 below).

C.8 HULL APPENDAGES

C.8.1 DAGGERBOARD

C.8.1.1 MANDATORY

- (1) One **daggerboard**

C.8.1.2 DIMENSIONS (see also E.3.3)

	minimum	maximum
Extension of <b>daggerboard</b> below the underside of the keel (excluding keelbands) .....	.....	597 mm

C.8.1.3 USE

- (a) The **daggerboard** shall be retained within the **daggerboard** case by one or more pieces of shockcord attached to the **hull**.

C.8.2 RUDDER ASSEMBLY

C.8.2.1 MANDATORY

- (1) One **rudder** blade
- (2) One **rudder** stock
- (3) One tiller

C.8.2.2 OPTIONAL

- (1) One fixed-length tiller extension

C.8.2.3 DIMENSIONS (see also E.4.3)

	minimum	maximum
Leading edge of <b>rudder</b> blade when in vertical position parallel with Datum Plane "A" from aftermost part of skag .....	.....	55 mm
Tiller length when in stock positioned fore and aft, from <b>Hull Datum Point</b> .....	.....	800 mm
<b>Hull Datum Point</b> to tip of <b>rudder</b> at lowest position.....	710 mm	790 mm



- C.8.2.4 USE
- (1) The blade shall be pivoted in the stock and be free to move through an arc of not less than eighty degrees about its pivot except when held in the up or down position by a spring device, lanyards or friction nut.
  - (2) The blade shall be held in position about its pivot by a spring, lanyard(s) or friction nut.
  - (3) The **rudder** shall be fitted to the **hull** so that it shall not part company with the **hull** during a capsize.
  - (4) The tiller shall be secured to the **rudder** stock.
- C.9 RIG**
- C.9.1 MAST  
USE
- (a) The aft face of the **mast** at the **mast datum point** (see F.2.2) (including any sail track, extended if necessary) shall be not less than 2140mm nor more than 2180mm from the **hull datum point** (see D.1.5).
  - (b) The **mast** foot position and effective shroud lengths shall not be adjusted while a **boat** is racing.
  - (c) **Mast** tenon socket and **mast** tenon shall not prevent the **mast** resting on the upper face of the **mast** step.
- C.9.3 BOOM  
USE
- (1) The intersection of the aft edge of the mast **spar** and the upper edge of the boom **spar**, each extended as necessary, shall not be below the upper edge of the mast **lower limit mark** when the boom **spar** is at 90° to the mast **spar**.
- C.9.4 RUNNING RIGGING
- (a) USE - MANDATORY
    - (1) The mainsail sheet may have either:
 

STERN SHEETING: the mainsheet shall be led from an eye or fairlead on the transom through a single block attached at or within 100mm of the end of the **boom spar** and then through a single block attached to the transom and then to the hand. Or

CENTRE SHEETING: The mainsheet shall be led through a block (“A”) fixed centrally a minimum of 1368mm and a maximum of 1493mm forward of Datum Plane “A” then up to a single block (“B”) attached to the **boom spar** 680mm - 800mm from the aft side of the mast. It shall then pass through at least one soft loop (300mm - 400mm aft of block “B”) and around a block attached at or within 100mm of the end of the **boom spar**. At some point the mainsheet shall divide into two legs each of which shall be attached to the transom points.

In either system the **mainsail** sheet may be attached to the **hull** with shackles, swivel link, knots and/or plastic bobbles or stoppers.
    - (2) The **headsail** sheet(s) shall be attached to the **headsail** with a knot or knots and/or a shackle or swivel link and shall be sheeted through the **headsail** fairleads.
    - (3) The **mainsail halyard** may be attached to the sail with a shackle, swivel link or a knot and/or a plastic bobble or stopper.
    - (4) The **headsail halyard** may be attached to the sail with a shackle, swivel link or a knot and/or a plastic bobble or stopper. The **headsail halyard** block may be attached to a wire strop but the distance between the **mast spar** mid band and the centre of the sheave of the block shall not exceed 250mm. Metal or plastic thimbles are permitted to reinforce the **halyards** at the purchase.
    - (5) A kicking strap shall be fitted with a mechanical advantage of not more than 6:1. It may be fitted with one cleat and appropriate blocks, fairleads, lines, wire and attachment and other fittings. The blocks, fairleads, fittings, and cleat may be attached to the **boom**, or the **hull** or may be incorporated in the purchase system or its blocks and the methods of attachment are optional.
    - (6) No gearing of the spinnaker **halyard** is permitted.
  - (b) OPTIONAL
    - (1) A **mainsail** Cunningham may be fitted consisting of no more than a line, two fairleads or fairleading blocks and one cleat. The line, fairleads, fairleading blocks and cleat may be

attached to the **mainsail**, the **mast**, or the **hull** and the methods of attachment are optional.

- (2) A **mainsail** outhaul may be fitted with a mechanical advantage not exceeding 4:1. It may be fitted with one cleat and appropriate blocks, eyes, bobbles and lines. The cleat must be fitted on the **boom spar**.
- (3) A **headsail** Cunningham may be fitted consisting of no more than a line, fairlead or fairleading block and one cleat. The line, fairlead, fairleading block and cleat may be attached to the **headsail** or to the foredeck and the methods of attachment are optional.
- (4) Spinnaker pole up haul/down haul.
- (5) The spinnaker **halyard** may be attached to the sail with a shackle, swivel links, clips or knots and/or a plastic bobble or stopper.
- (6) A plastic bobble or stopper may be used between the attachment of the spinnaker **halyard** and the spinnaker **halyard** fairlead on the mast.
- (6) Spinnaker sheet(s) which may be attached to the spinnaker with shackles, swivel links, clips or knots and/or plastic bobbles or stoppers..
- (7) A burgee **halyard** may be fitted, led through an eye at the top of the mast and cleat on the mast. Alternatively a burgee clip or bracket may be fitted.
- (8) The tails of the **halyards** may be tied off to any fitting or to a piece of shockcord attached to any fitting, but not so as to create any gearing or hoisting system.

## C.10 SAILS

### C.10.1 MODIFICATIONS, MAINTENANCE AND REPAIR

- (a) **Sails** shall not be altered in any way except as permitted by these **class rules**.
- (b) Routine maintenance such as cleaning and the repair of minor faults which do not alter the shape of the **sail** is permitted without re-**certification**. Any other repairs or alterations shall require the **sail** to be re-**certified**.

### C.10.2 LIMITATIONS

- (a) Only one **mainsail**, one **headsail** and one **spinnaker** may be carried on board.

### C.10.3 MAINSAIL

#### (a) IDENTIFICATION

The class insignia shall be the letter C. The insignia, national letters and sail numbers shall conform to RRS Appendix G1.2 and G.1.3 except that:

- (1) The dimensions specified in G.3.3 below shall apply to the height, width and thickness of the insignia, letters and numbers; and
- (2) The national letters and sail numbers shall be above an imaginary line projecting at right angles to the **luff** from a point 900mm from the **tack**.

#### (b) USE

- (1) The **sail** shall be hoisted on a **halyard**.
- (2) The highest visible point of the **sail**, projected at 90° to the mast **spar**, shall not be set above the lower edge of the mast **upper limit mark**. The intersection of the **leech** and the top of the boom **spar**, each extended as necessary, shall not be behind the fore side of the boom **outer limit mark**.
- (3) **Luff** and **foot** bolt ropes/shock cord and (if they are fitted) mast or boom sail slides shall be in the **spar** grooves or tracks.
- (4) The **tack** shall be attached to the **boom** or **mast** by a shackle, pin, lanyard or strap.
- (5) Reefs shall not be taken in, shaken out or adjusted while racing.

### C.10.4 HEADSAIL

#### (a) USE

- (1) The **tack** shall be attached to the stem head fitting by means of a lanyard, shackle or clevis pin so that the **tack point** of the **headsail** shall be aft of and a maximum of 50mm from Datum Line "C" at the centre of the fore transom.
- (2) The **sail** shall be hoisted on a **halyard**.

- C.10.5 SPINNAKER
- (a) IDENTIFICATION  
Sail numbers and national letters are not required. This modifies RRS G.1.1.
  - (a) USE  
The **sail** shall be hoisted on a **halyard**.

## Section D – Hull

### D.1 GENERAL

#### D.1.1 TYPES OF HULL

- (a) **Hulls** shall be one of the following types:
  - (1) Mark II.
  - (2) Mark III.
  - (3) Mark IV.

#### D.1.2 APPLICABLE RULES

- (a) The **hull** of a boat which is subject to initial **certification control** or re-**certification control** on or after 1<sup>st</sup> March 2009 shall comply with these **class rules**.
- (b) The **hull** of a boat which was subject to initial **certification control** or re-**certification control** before 1<sup>st</sup> March 2009 and which has not been subject to a Relevant Alteration or Repair (see D.1.3) after the date of such initial **certification control** or re-**certification control** shall comply with the **class rules** in force at the date of such initial **certification control** or re-**certification control** (whichever is later). Such a **hull** need not comply with D.1.1, D.1.2(e), D.1.7, D.1.8, D.1.9, D.2 - D.8 or D.10 of these rules, but shall comply with D.1.4, D.9.1 and D.9.2. D.1.2(d) and D.9.3 shall apply to such a **hull**.
- (c) The **hull** of a boat which has been subject to a Relevant Alteration or Repair is required to be re-measured and **re-certified**, and it shall comply with the **class rules** in force at the time of its re-measurement and re-**certification**.
- (d) Where the **hull** of a boat is required to comply with the **class rules** in force at the date of its initial **certification control** or re-**certification control** and that date was between 28<sup>th</sup> February 1974 and 28<sup>th</sup> February 2009, then the exterior of its **hull** is not required to comply with those measurements set out in the Tables on Measurement Plan No.1 which were current at that date and which were not also measurements which were required to be checked by the Registration Form and/or Check List and/or Measurement Form and/or Measurement Supplement which was required to be successfully completed in order to lead to the issuing of such boat's Measurement **Certificate**.
- (e) Mark IIs and Mark IIIs shall comply with the requirements of the Wooden Boat Supplement at H.1.

#### D.1.3 DEFINITIONS

- (a) A Relevant Alteration or Repair is any alteration or repair other than a Permitted Repair or permitted routine maintenance such as painting and polishing.
- (b) Permitted Repairs are minor repairs which do not alter the shape of the **hull** and provide no advantage. Examples of some things which are or are not minor repairs are listed in H.9.

#### D.1.4 MODIFICATIONS, MAINTENANCE AND REPAIR

- (a) The **hull** shall not be altered in any way except as permitted by these **class rules**.
- (b) Permitted Repairs are permitted.
- (c) Routine maintenance such as painting and polishing is permitted.
- (d) Internal details of construction of the **hull** may be varied as considered necessary by the builder to suit the materials and/or building techniques used with the written approval of the Technical Committee of the ICA.

#### D.1.5 DATUM DEFINITIONS

<b>Hull Datum Point</b>	The <b>hull datum point</b> (sometimes referred to as "Datum Point 'A'") is the intersection of the projection of the external surface of the aft transom with the upper
-------------------------	--

	surface of the deck at the centreline.
Datum Plane "A"	Datum Plane "A" is the <b>vertical</b> plane that runs through <b>Hull Datum Point</b> and is perpendicular to Datum Line "B".
Datum Line "B"	Datum Line "B" is the <b>longitudinal</b> baseline along the centreline of the hull, at right angles to Datum Plane "A" and at the following vertical distances below the lower surface of the keel (excluding the keelband): (i) At section 3, 2134mm from Datum Plane "A": vertical distance: 76mm. (ii) At section 8, 610mm from Datum Plane "A": vertical distance: 140mm
Datum Plane "B"	Datum Plane "B" is the <b>transverse</b> plane containing Datum Line "B"
Datum Line "C"	Datum Line "C" is the projected intersection of the external surface of the <b>hull</b> with the upper surface of the deck.
Datum Plane "E"	Datum Plane "E" means the plane which passes through Datum Line "C" and which is coincident with the straight edge (and its straight extensions) used to find Datum Line "C" when that straight edge is used for that purpose all around the hull

The projection of the aft transom and the projection of the hull at **Hull Datum Point** and Datum Line "C" shall be established using a straight edge with a keyhole cut out (for the moulding flange or rubbing strake or bead or any irregularities within 50mm of Datum Line "C") and so that the bottom of the cut out at the straight edge is 50mm from Datum Line "C" and the straight edge continues for 180mm beyond the bottom of the cut out at the straight edge. Measurement Plan No.2 contains an illustrative drawing.

#### D.1.6 IDENTIFICATION

- The hull shall carry the ISAF Plaque permanently placed on the inside of the aft bulkhead in Mark II and Mark III boats and on the inside of the transom in GRP MkIV boats.
- The sail number of the boat shall be permanently marked in contrasting colour (carved or engraved) on the port side of the outside of the transom in figures of a minimum of 25mm in height.

#### D.1.7 HULL DIMENSIONS

- The exterior shape of the hull of all Marks shall comply with the dimensions shown in the following Tables:

SECTION NUMBER OR MEASUREMENT STATION	LOCATION OF SECTION FROM DATUM PLANE "A"	MEASUREMENTS FROM DATUM PLANE "B"			MEASUREMENTS OF BEAM	
		TO KEEL	TO CHINE	TO DATUM LINE "C"	BEAM AT DATUM LINE "C"	BEAM AT CHINE
FORE TRANSOM		-	-	680 - 707	320 - 340	-
FORE TRANSOM		-	359 - 383	-	-	152 - 168
FORE TRANSOM		331 - 361	-	-	-	-
1	2743	184 - 208	235 - 301	623 - 661	743 - 783	500 - 594
2	2438	109 - 133	187 - 251	599 - 633	966 - 1006	745 - 816
3	2134	76	189 - 205	575 - 599	1125 - 1155	928 - 952
4	1829	48 - 72	184 - 204	547 - 587	1207 - 1247	1020 - 1050
5	1524	58 - 75	195 - 211	528 - 568	1245 - 1285	1080 - 1104
6	1219	71 - 95	210 - 234	512 - 552	1232 - 1272	1084 - 1114
7	914	96 - 120	229 - 253	503 - 543	1194 - 1234	1058 - 1088
8	610	140	263 - 279	502 - 526	1125 - 1155	1004 - 1028
9	305	166 - 190	284 - 310	493 - 523	1029 - 1069	931 - 961
AFT TRANSOM		-	-	490 - 520	934 - 958	-
AFT TRANSOM		-	306 - 328	-	-	839 - 863
AFT TRANSOM		202 - 224	-	-	-	-
Sections are parallel with Datum Plane "A". Chine measurement points are the intersections of the flat outer surfaces of the panels as shown on Measurement Plan 2. Measurement points at the fore and aft transoms shall be found by extending the relevant surfaces ignoring any variations within 50mm of the measurement points.						
<b>ALL DIMENSIONS ARE IN MILLIMETRES</b>						
NOTE: there are no tolerances on the Datum Plane "B" to keel measurements at sections 3 and 8 because these are part of the definition of Datum Line "B"						

From	To	Minimum	Maximum
<b>Hull Datum Point</b>	Datum Line "C" at the fore transom on the centreline (measured in a straight line between the two points)	3201mm	3251mm
Datum Plane "A"	The point of intersection on the centreline of the extension of the outer surface of the fore transom with the extension of the lower surface of the keel (ignoring any permitted rounding)	3067mm	3117mm
Datum Plane "A"	The aft edge of the keel where it joins the aft transom	46mm	56mm
<b>Hull Datum Point</b>	The straight line joining Datum Line "C" at the aft transom on one side of the boat with Datum Line "C" at the aft transom on the opposite side of the boat (Datum Line "C" being established for this purpose by reference to the top side panels of the hull)	-	50mm
Datum Line "C" on the centreline at the fore transom	The straight line joining Datum Line "C" at the fore transom on one side of the boat with Datum Line "C" at the fore transom on the opposite side of the boat (Datum Line "C" being established for this purpose by reference to the top side panels of the hull)	-	30mm

Item	Minimum	Maximum
Chine angle at section 3	114°	122°
Chine angle at section 8	114°	122°
Panel thickness (which may be variable and including any g.r.p., epoxy, filler, paint and varnish finishing)	-	20mm

#### D.1.8 HULL SHAPE

- (a) A straight edge 300mm long placed athwartships anywhere on the outer surfaces of the side or bottom panels (save (i) within 4mm of the edges of such panels and (ii) within 40mm of Datum Line "C") shall nowhere be more than 3mm from the hull surface.
- (b) A straight edge 300mm long placed anywhere on the outer surfaces of the bow or aft transoms (save (i) within 4mm of their edges and (ii) within 40mm of Datum Line "C") shall nowhere be more than 3mm from such surfaces.
- (c) Except where otherwise specifically permitted, any rounding on the chines or intersection of planes on the outside of the **hull** shall not extend beyond 4mm from the point of intersection of the two adjacent planes.

#### D.1.9 HULL MATERIALS

- (a) Except as permitted by (b), (c) and (d) of this rule or by the Wooden Boat Supplement at H.1, Mark II and Mark III **hulls** shall be built out of timber (either solid or plywood), provided that Mark II and Mark III **hulls** which were subject to initial certification before 1<sup>st</sup> March 1998 and which at that time were built out of some other material or materials may remain built out of that material and for so long as they do so they shall not be required to conform to the timber requirements of this rule or to the requirements of the Wooden Boat Supplement, notwithstanding that they have been subject to a Relevant Alteration or Repair.
- (b) The glue used in wooden construction is optional.
- (c) Screws, nails, rivets, nuts and bolts may be used as fastenings.
- (d) The exterior and interior of a hull may be finished with g.r.p., epoxy resin, filler, paint and varnish.
- (e) Mark IV hulls shall be built only out of g.r.p. (glass reinforced plastic) in accordance with a specification approved by the ICA Technical Committee and included within the licence granted to the builder, which specification may permit foam or wood cores and parts.
- (f) Any g.r.p. used shall consist only of polyester resin and E-Glass (in chopped strand or woven form).

D.1.10 BUILDERS

- (a) Mark IVs shall only be built by licensed builders from licensed moulds.
- (b) Mark IIs and Mark IIIs may be built by professional and amateur builders without licence.

**D.2 DECKS AND BULKHEADS**

D.2.1 For Mark IIs:

- (1) There shall be full fore and aft decks covering the buoyancy compartments.
- (2) There shall be one full width fore bulkhead and one full width aft bulkhead.
- (3) The external surfaces of the forward and aft bulkheads shall be so flat that a straight edge 300mm long placed anywhere on them (save within 4mm of their upper edges where they may be rounded) shall nowhere be more than 3mm from the surfaces. (4) The fore deck and aft deck shall extend to but not beyond the edges of the fore and aft bulkheads respectively.
- (5) There shall be side decks the full length between the fore and aft bulkheads.
- (6) Each side deck shall have an upper surface (in this rule referred to as “the flat upper surface”) extending inboard from Datum Line “C” for a minimum of 325mm measured athwartships and such that a straight edge 300 mm long placed anywhere and at any angle on that surface shall nowhere be more than 3mm from that surface.
- (7) The upper surfaces of the carlines may form part of the flat upper surface but shall not extend above it or its straight line extensions.
- (8) The spacing and sizes of deck beams and stringers is optional provided that in any section running athwartships and perpendicular to the flat upper surface of a side deck, the deck beams and stringers shall not project more than 50 mm below the flat upper surface or its athwartships extension measured perpendicular to the flat upper surface.
- (9) In any section running athwartships and perpendicular to the flat upper surface of a side deck, the carlines shall not project more than 50 mm below the flat upper surface or its athwartships extension measured perpendicular to the flat upper surface.
- (10) In any athwartships section, the inboard edge of the flat upper surface of a side deck (including the carline) shall be above and not more than 25mm above the straight line from Datum Line “C” on one side of the boat to Datum Line “C” on the opposite side of the boat at that section.
- (11) The upper surface of the side deck and the carlines may be rounded inboard of 335mm from Datum Line “C” measured athwartships.
- (12) A straight edge 300 mm long placed anywhere on the upper surfaces of the fore or aft decks parallel with the centerline and inside Datum Line “C” (save within 4mm of the aft edge of the foredeck and within 4mm of the fore edge of the aft deck where those decks may be rounded) shall nowhere be more than 3mm from the surfaces.
- (13) A string pulled taut across any athwartships section of the upper surfaces of the fore or aft decks shall nowhere be more than 3mm away from those surfaces.
- (14) The decks and bulkheads shall comply with the dimensions in the following table:

Mark IIs			
From	To	Minimum	Maximum
Datum Plane "A"	Aft surface of the forward bulkhead	2114mm	2170mm
Datum Plane "A"	Forward surface of the aft bulkhead	600mm	629mm
Plan width of side decks excluding any part outside Datum Line "C", but including the carlines		-	355mm
Flat upper surface of side decks (as defined above), in board of Datum Line "C", measured athwartships		325mm	-
Upper surface of the fore deck at the centreline at the aft edge of the forward bulkhead above the straight line from Datum Line "C" on one side of the boat to Datum Line "C" on the opposite side of the boat at that athwartships section		0mm	46mm
Upper surface of the aft deck at the centreline at the forward edge of the aft bulkhead above the straight line from Datum Line "C" on one side of the boat to Datum Line "C" on the opposite side of the boat at that athwartships section.		0mm	50mm

- D.2.2 For Mark IIIs:
- (1) There shall be fore and aft decks and bulkheads which comply with the requirements of D.2.1.
  - (2) The side deck structure shall be as described below and illustrated on diagrams A & B on Measurement Plan No.5.
  - (3) At any point between 650 mm and 2100 mm forward of Datum Plane "A", the horizontal width of the side deck structure, including the rubbing bead, measured to a point 25 mm below the top of the deck surface shall be between 210 mm and 240 mm. The deck surfaces in any transverse section shall not fall below Datum Line "C" nor rise more than 25 mm above it.
  - (4) There shall be finger grips or grab slots on each side at least 20 mm deep extending along the length of the sidedeck at least between 750 mm and 2100 mm from Datum Plane "A".

- D.2.3 For Mark IVs:
- (1) The fore deck, side decks and forward bulkhead shall be as shown in the respective specification/measurement supplement.
  - (2) There shall be finger grips or grab slots on each side approximately 20mm high / deep and running substantially from 610mm to 1524 mm from Datum Plane "A".

### **D.3 BUOYANCY TANKS**

#### **D.3.1 CONSTRUCTION**

- (a) For Mark IIs the buoyancy compartments shall be constructed by the full width forward and aft bulkheads and the fore and aft decks.
- (b) For Mark IIIs buoyancy equipment shall consist of (i) the same watertight compartments as are required for Mark IIs and (ii) watertight compartments under the side decks between the fore and aft bulkheads.
- (c) Mark IV buoyancy equipment shall comprise separate fore and side tanks as per the official mouldings.
- (d) One inspection hole of circular shape of minimum diameter (including fixed part of inspection hole fitting) 90mm and maximum diameter (including fixed part of inspection hole fitting) 150mm shall be provided in each buoyancy compartment. A second inspection hole of the same shape and minimum and maximum dimensions may be fitted in the fore and aft bulkheads.
- (e) Drain holes are optional.
- (f) Each inspection hole and drain hole shall be provided with a suitable detachable cover or stopper capable of resisting accidental dislodgement by any means.

### **D.4 GUNWALE RUBBING BEADS**

#### **D.4.1 MATERIALS**

- (a) Subject to the special exceptions mentioned in D.4.3 below, Mark IIs and Mark IIIs shall have rubbing beads which shall be made of g.r.p., plastic or wood.
- (b) Mark IVs shall not have separate rubbing beads, but shall have g.r.p. deck overhangs or flanges.

#### **D.4.2 CONSTRUCTION AND DIMENSIONS**

- (a) Subject to the special exceptions mentioned in D.4.3 below, Mark IIs and Mark IIIs shall have rubbing beads or deck overhangs which:
  - (i) At the edge of the decks from fore transom to aft transom shall have a depth measured along Datum Plane "E" of between 18mm and 25mm.
  - (ii) At the edge of the decks from fore transom to aft transom shall extend for a minimum of 8mm and a maximum of 50mm from Datum Line "C" measured perpendicular to Datum Plane "E" at the points on Datum Line "C" from which the measurements are taken; save that within 25mm of the fore and aft transoms they may be tapered or rounded down to 0mm.
  - (iii) Within the specified dimensions may be tapered.
- (b) Mark IVs shall have deck overhangs or flanges which:
  - (i) Shall not project above Datum Line "C".
  - (ii) At the edge of the decks from fore transom to aft transom shall extend for a minimum of 25mm and a maximum of 50 mm from Datum Line "C" measured perpendicular to Datum Plane "E" at the points on Datum Line "C" from which the measurements are taken.
  - (iii) At the fore transom shall extend for a minimum of 25mm and a maximum of 65 mm

- from Datum Line "C" measured perpendicular to Datum Plane "E" at the points on Datum Line "C" from which the measurements are taken.
- (iv) At the aft transom shall extend for a minimum of 14mm and a maximum of 30 mm from Datum Line "C" measured perpendicular to Datum Plane "E" at the points on Datum Line "C" from which the measurements are taken; save that 100mm on either side of the centreline they may be cut away to 0mm.
  - (v) Within the specified dimensions may be tapered.

#### D.4.3 SPECIAL EXCEPTION FOR SOME OLD MARK IIs and IIIs

- (a) Mark IIs or Mark IIIs which (i) were subject to initial fundamental measurement before 1<sup>st</sup> January 1998, and (ii) were substantially built (either as to the hull shell alone or as to the decks alone or as to both) out of g.r.p., and (iii) had their rubbing beads integrally moulded, shall, notwithstanding that they may have been subject to a Substantial Alteration or Repair, at their option either conform to the requirements as regards rubbing beads which applied to them at the time of their initial fundamental measurement or comply with the requirements of D.4.1 and D.4.2.

### D.5 KEEL, SKEG AND DAGGERBOARD CASE

#### D.5.1 CONSTRUCTION AND DIMENSIONS

- (a) The keel shall run continuously from the fore transom to the aft transom.
- (b) In this rule (D.5.1) "flat" means that if a straight edge 300mm long is placed on the surface in question the surface shall nowhere be more than 2mm from the straight edge.
- (c) Save for rounding as permitted below, the lower surface of the keel (excluding the keel band) shall be flat athwartships.
- (d) Save for permitted rounding the sides of the keel shall be flat.
- (e) The flat sides of the keel shall be at  $90^\circ \pm 5^\circ$  to the flat part of the lower surface of the keel.
- (f) Except for permitted rounding the keel shall not vary in thickness or width throughout its length by more than 5mm.
- (g) Save for permitted rounding, the aft ends of the keel and skeg shall be so flat and so in line with the outer face of the aft transom that a straight edge placed anywhere on such surfaces within 200mm of the point where the keel joins the transom shall nowhere (save at the permitted rounded parts) be more than 2mm from such surfaces.
- (h) Save for permitted rounding, the fore end of the keel shall be so flat and so in line with the outer face of the fore transom that a straight edge placed anywhere on such surfaces within 200mm of the point where the keel joins the transom shall nowhere (save at the permitted rounded parts) be more than 2mm from such surfaces.
- (i) The side and bottom surfaces of the skeg shall be flat save that within 4 mm of where the two planes meet, the corners may be rounded.
- (j) The skeg shall start at a point not less than 965 mm or more than 1005 mm forward from Datum Plane "A" and shall run aft to the aft end of the keel.
- (k) The components shall comply with the following and rounding or radissussing is permitted as indicated:

Item	Max.	Min.
Width of keel throughout its length (measured between its flat surfaces)	90mm	76mm
Thickness of keel throughout its length	25mm	11mm
Width of skeg, upper surface in contact with keel at aft end		38mm
Width of skeg, upper surface in contact with keel at forward end		20mm
Width of the flat part of the lower surface of the skeg (measured as if it was not rounded where there is permitted rounding)		19mm
Depth of skeg near aft end (including keelband to the lowest point on the keelband)		76mm
Radius at fore end of keel and aft end of skeg	30mm	20mm
Radius at edges of keel throughout its length	10mm	
Radius where bottom panels meet keel	6mm	
Radius where skeg meets keel	6mm	

- (l) The **daggerboard** slot and case shall comply with the dimensions in the following table:

From	To	Minimum	Maximum
Datum Plane "A"	Forward end of <b>daggerboard</b> slot	1835mm	1885mm
Datum Plane "A"	Aft end of <b>daggerboard</b> slot	1518mm	1568mm
Top of <b>daggerboard</b> case	Bottom surface of keel (excluding keelbands), mid-way between each end of the inside of the <b>daggerboard</b> case	290mm	-
Width of <b>daggerboard</b> case (internal)		15mm	20mm



- (m) Except as permitted by (n) and (o) below, the width of the daggerboard slot shall not vary by more than 2mm.
- (n) Strips of non-metallic material may be fitted in the **daggerboard** slot within 30mm of the top and bottom of the slot but not so as to cause the width of the opening to vary by more than 2mm. Additional non-metallic material may be fitted within 30mm of each end of the slot.
- (o) The **daggerboard** slot may be rounded within 9mm of each end.

## **D.6 RUBBING BANDS**

### **D.6.1 MATERIALS**

- (a) Rubbing bands of brass, light alloy or plastic shall be fitted to the keel, skeg and chines.

### **D.6.2 CONSTRUCTION**

- (a) Rubbing bands shall be of convex or flat section strip.
- (b) Rubbing bands, where required, shall not be tapered and shall have a minimum cross-sectional dimension of 10mm by 2mm and a maximum cross-sectional dimension of 30mm by 8 mm. Outside the mandatory places tapering is optional.
- (c) The keel band(s) shall run the full length of the keel and skeg (which includes the forward edge of the keel and the after edges of the keel and skeg), except that when a self bailer is fixed in the keel they may begin and end not more than 40mm fore and aft of the self bailer. They shall be double for at least the full length of the **daggerboard** slot and may be double elsewhere or triple within 100mm of the fore and aft ends of the **daggerboard** slot.
- (d) The chine bands shall be a minimum length of 1219 mm each (measured around the chine), positioned a minimum of 600mm from the aft transom. The outboard edges of the chine bands shall (except where they may be tapered) be within 4mm of the intersections of the flat outer surfaces of the panels as shown on Measurement Plan No.2.
- (e) The keel and chine bands of Mark IVs may be integrally moulded with the hull in which case they shall be treated as existing outside the extensions of the flat lower surface of the keel or the bottom panels as appropriate.

## **D.7 THWART**

### **D.7.1 MATERIALS**

- (a) A thwart made of wood or g.r.p. shall be fitted.

### **D.7.2 CONSTRUCTION**

- (a) The thwart shall have a minimum width of 102mm.
- (b) The thwart shall extend the full width of the boat or fully between the side tanks on the Mk III and Mk IV boats.
- (c) The aft edge of the thwart shall be a minimum of 1416mm and a maximum of 1470mm forward of Datum Plane A.
- (d) The thwart shall be fixed to or part of the **daggerboard** case or capping.
- (e) The specification of the thwart riser is optional.
- (f) An aft extension of the thwart of maximum dimensions 250mm (athwartships) by 75mm (fore and aft) on the centreline is permitted.

## **D.8 SPLASH OR SPRAY GUARDS**

### **D.8.1 GENERAL**

- (a) Splash or spray guards shall be provided on the foredeck, one each side of and joined at the centreline and running at least to Datum Line "C".

### **D.8.2 MATERIALS**

- (a) For Mark IIs and Mark IIIs with wooden decks the guards shall be of wood.
- (b) For Mark IIs and Mark IIIs with g.r.p. decks the guards shall be wood or g.r.p.
- (c) For Mark IVs the guards shall be g.r.p.

### **D.8.3 CONSTRUCTION**

- (a) For Mark IIs and Mark IIIs the minimum length of each guard shall be 820 mm, minimum height above the deck at the centre line 38 mm and tapering in a straight line to a minimum height of 19mm above deck at 820mm from their joint at the centreline. They shall be fitted or moulded to the foredeck. The section through the guards shall have a minimum base width of 12 mm, and a minimum radius to the top edge of 3 mm.
- (b) For Mark IVs the splash or spray guards shall be incorporated in the deck moulding and shall be as specified in the Mark IV measurement supplement or form.

## D.9 FITTINGS

### D.9.1 MATERIALS

The fittings may be made of any materials but their general design shall not be altered so as to incorporate other uses. Measurement Plan No. 4 is illustrative only. The fittings may be of a different design to those illustrated on Measurement Plan No.4, but their general design shall not be altered so as to incorporate other uses.

### D.9.2 MANDATORY

The following items are mandatory:

- (i) A **mast** step block, fitting, or hole which complies with the following:
  - I. The upper face of the step (including optional protective plate, if fitted) shall be not more than 46mm above the straight lines joining Datum Line “C” on the port and starboard sides of the **hull** at the sections containing the step which are parallel with Datum Plane “A”.
  - II. The step shall include a socket for the **mast** tenon.
  - III. The lateral and fore and aft bearing surfaces of the **mast** tenon socket shall lie between the outside of a 28mm X 28mm horizontal square and the inside of a concentric 30mm X 30mm horizontal square.
  - IV. The **mast** tenon socket shall be a minimum of 13 mm deep.
- (ii) A towing fitting made of stainless or galvanised steel shall be strongly attached to the fore transom at least 230 mm below Datum Line “C” at the top of the fore transom.
- (iii) A bow plate to attach the forestay and **headsail** shall be fitted on the centreline at the bow.
- (iv) Two **hull** shroud plates or U bolts shall be fitted a minimum of 1810mm and a maximum of 1860mm from Datum Plane “A” (a minimum of 1813 and maximum of 1863mm if measured along deck).
- (v) Two **headsail** fairleads shall be fitted. They may be combined with the **hull** shroud plates or fixed to the deck so that the bearing surface of the fairlead is a maximum of 50 mm from Datum Line “C”.
- (vi) Separate **halyard** cleats for the **mainsail** and **headsail halyards** shall be fixed on the forward bulkhead.
- (vii) For the stern sheeting arrangement, a single free running block or a fairlead, and a fixed eye for the mainsheet shall be fixed a minimum of 244mm and a maximum of 264mm either side of the boat centreline on the deck at the aft transom. The single block may incorporate a swivel fitting.
- (viii) For the centre sheeting arrangement: a single block (“A”) (which may be of ratchet type and which may incorporate or be attached by a swivel fitting) shall be fixed centrally a minimum of 1368mm and a maximum of 1493mm forward of Datum Plane “A” and attachment eyes or fairleads shall be fixed a minimum of 244mm and a maximum of 264mm either side of the boat centreline on the deck at the aft transom.
- (ix) Gudgeons and/or pintles for the rudder shall be fitted on the aft transom. A retaining clip or device attached to the aft transom or to a fixed or loose pintle shall be fitted so as to prevent the rudder from becoming accidentally detached while in use.
- (x) Toe straps shall be fixed in the hull for the crew and helmsperson. They may be fixed or adjustable, positioned to suit. The toe strap webbing may be of optional length and width. The ends of the toe straps shall be attached to the hull or bulkheads in an appropriate manner. For this purpose and for the purpose of adjustment only ropes, fairleads, deckeyes, cleats, and appropriate pads, plates and fastenings may be used.
- (xi) Inspection hole fittings consisting of a part fixed to the **hull** and a detachable cover are required.
- (xii) Shock cord shall be fitted and fixed for retaining the **daggerboard** in the **daggerboard** case.

- (xiii) A kicking strap eye plate must be fitted on the centreline, and may be combined with the mast plate.

#### D.9.3 OPTIONAL

The following items are optional:

- (i) Two **headsail** sheet cam cleats may be fitted inboard of the **headsail** sheet fairlead and placed a minimum of 1735 mm from Datum Plane "A" measured along the deck.
- (ii) Mainsail Cunningham block, fairlead and cleat.
- (iii) Fairleads for the spinnaker sheets (when fitted) must be fitted between 690mm and 1120mm from Datum Plane "A" measured along the deck. One open cleat for the spinnaker sheet may be fitted on each side of the boat between 690mm and 1120mm from Datum Plane "A" measured along the deck. One additional cleat for the spinnaker sheets may be fitted on each side of the boat and may be incorporated with the open fairlead referred to in D.9.3(xi) or the shroud plates or U bolts or the shroud adjusting plates. The cleats shall not extend beyond the outside of the rubbing strake or bead or deck flange or overhang.
- (iv) A maximum of two lacing hooks are permitted to hold the spinnaker **halyard**.
- (v) If a spinnaker **halyard** is fitted its tail after passing through the fairlead on the mast shall be led through no more than the following: (i) one cleat (which may incorporate a fairlead, which fairlead shall not count towards the number of fairleads next-mentioned); (ii) a maximum of two fairleads or single blocks. The cleat may be fitted in any position. No gearing of the spinnaker **halyard** is permitted.
- (vi) Lifting handles are optional, but if fitted, four handles made of suitable material shall conform to the dimensions shown on Measurement Plan No.3 and shall be strongly fitted so that the centres of the aft pair of handles are 640mm  $\pm$ 50 mm from Datum Plane "A" and the centres of the forward pair of handles are 2370mm  $\pm$ 50 mm from Datum Plane "A".
- (vii) A maximum of two self-bailers are allowed.
- (viii) It is permissible to have one or two open compartments or bags (for spinnaker or other loose gear), provided that they extend aft no more than 400mm from the forward bulkhead. The compartments or bags may be partly covered by flexible material which may be supported by shockcord. The bags may contain pockets and be supported by shockcord.
- (ix) Stowage clips, nets, ropes, bags and shockcord (and their fastenings) for paddle(s), spinnaker pole, sail bags and other loose equipment.
- (x) Drain hole fittings of internal dimensions 20 mm ( $\pm$  5 mm) may be provided in each buoyancy compartment.
- (xi) A protective plate may be fixed to the mast step so as to form the upper surface.
- (xii) One open fairlead may be fitted on each side of the boat to fairlead the spinnaker sheets. It shall not project beyond the gunwale.
- (xiii) One compass of the type permitted under C.5.1(b) and mounting bracket only may be fitted. If a compass is fitted to the **hull** no other compass may be carried.
- (xiv) Optional blocks cleats and fairleads for the operation of a spinnaker pole uphaul / downhaul system.
- (xv) A block, fairlead and cleat for the jib Cunningham may be fitted on the foredeck.
- (xvi) Blocks, fairleads and cleat for kicking strap system.
- (xvii) Plastic bobbles or stoppers for use in conjunction with knots.
- (xviii) Shock cord may be fitted at or near the transom so as to prevent the mainsheet from catching on the corners of the transom.
- (xix) Shock cord may be fitted to support the toe straps.
- (xx) Such fastenings and ropes as may be appropriate in order to attach permitted fittings or equipment.

- (xxi) The use of shock cord or adhesive tape is in general unrestricted, except that such material must not be used in such a way as to create a fitting or extend a function which is otherwise prohibited in these rules.

**D.10 WEIGHT, CORRECTORS AND CENTRE OF GRAVITY**

**D.10.1 WEIGHT**

	<b>minimum</b>	<b>maximum</b>
The weight of the <b>hull</b> in dry condition .....	54 kg	..... kg

The weight shall be taken with fixed fittings (including compass and compass bracket if fitted to **hull**, and inspection and drain hole covers or bungs) and **corrector weights**, but stripped of all loose gear such as **sails, spars, hull appendages**, rigging, separate buoyancy and all portable equipment as listed in C.5.

**D.10.2 CORRECTOR WEIGHTS**

- (a) For Mark II type **boats, corrector weights** shall be of wood and shall be fastened under the side decking amidships close to the carlin.
- (b) For Mark III and Mark IV type **boats, corrector weights** shall be of lead and shall be bonded or bolted to the underside of the thwart.
- (c) The total weight of **corrector weights** for Mark IV type **boats** shall not exceed 3 kg.

**D.10.3 CENTRE OF GRAVITY**

- (a) For the purposes of this rule the **hull** shall be in its condition for taking its weight and shall include any **corrector weights**.
- (b) The centre of gravity of the **hull** shall not be lower than 177mm below the gunwale. The **hull** when supported on one gunwale shall be in balance when the opposite gunwale is not more than 340mm beyond the vertical.
- (c) The **hull** shall be supported upside down on an athwartships round bar positioned 915mm forward of the **hull datum point**. With the deck line level, the weight of the bow when suspended from the towing fitting shall not be a minimum of 25% of the measured weight and a maximum of 30% of the measured weight.

# Section E – Hull Appendages

## E.1 PARTS

### E.1.1 MANDATORY

- (a) One **daggerboard**.
- (b) One **rudder**.
- (c) One **rudder** stock.
- (d) One tiller.

### E.1.2 OPTIONAL

- (a) One fixed-length tiller extension.

## E.2 GENERAL

### E.2.1 RULES

- (a) **Hull appendages** which (i) have been **certified** by way of a Class label and measurer’s signature under any earlier version of these rules and (ii) have not been subsequently altered or repaired otherwise than by way of routine maintenance such as painting and polishing and the repair of minor chips and abrasions, shall comply with the **class rules** in force at the date of such **certification**.
- (b) All other **hull appendages** shall comply with these **class rules**.

### E.2.2 MANUFACTURERS

- (a) The manufacturers of **hull appendages** are optional.

### E.2.3 CONSTRUCTION

- (a) The bottom edges of the **hull appendages** may be protected by a strip of metal or plastic of dimensions not exceeding 460mm long by 6mm deep with an exposed radius of not less than 3mm.
- (b) The **hull appendages** may be finished with g.r.p, epoxy resin, filler, paint and varnish.

## E.3 DAGGERBOARD

### E.3.1 MATERIALS

- (a) The **daggerboard** shall be of:
  - (1) Wood (solid or laminated)
  - (2) GRP or
  - (3) GRP with a core made from foam and/or any of the above or
  - (4) A combination of any of the above.
- (b) The material of the **daggerboard** capping is optional.

### E.3.2 CONSTRUCTION

- (a) The **daggerboard** shall be fitted with a suitable capping of optional material no less than 20mm deep; 35mm wide and extending at least the full fore and aft length of the board.

### E.3.3 DIMENSIONS

#### E.3.3.1 Below the capping, the athwartships profile of the **daggerboard** shall:

- (a) Fit within the profile ABCD shown on Measurement Plan No.3, and
- (b) At no point shall be more than 5mm from the straight lines A-B and C-D or the semi-circle B-C.

#### E.3.3.2 The **daggerboard** shall comply with the following:

	<u>Minimum</u>	<u>Maximum</u>
Total thickness of <b>daggerboard</b> .....	12mm	14mm
The bevel of the edges from the edge of <b>daggerboard</b> .....	-	29mm

Thickness variation of the <b>daggerboard</b> (except within the bevelled parts) .....	-	1mm
The radius of the leading and trailing edges .....	1.5mm	-

E.3.3.3 The maximum length of the **daggerboard** from the lowest point of the daggerboard to the nearest point on the underside of the capping shall be 887mm.

E.3.4 **WEIGHT**

- (a) The minimum weight of the **daggerboard** is 2.3 kg.
- (b) **Correctors** if required shall be permanently secured on top of the capping.

**E.4 RUDDER BLADE, RUDDER STOCK AND TILLER**

E.4.1 **MATERIALS**

- (a) The **rudder** blade shall be of:
  - (1) Wood (solid or laminated) or
  - (2) GRP or
  - (3) GRP with a core made from foam and/or any of the above or
  - (4) A combination of any of the above
- (b) The **rudder** stock material is optional.
- (c) The tiller material is optional.
- (d) The tiller extension material is optional.

E.4.2 **CONSTRUCTION**

- (a) The tiller may be of optional section and may be tapered.
- (b) **Rudder** uphaul and downhaul cleats may be fitted to the tiller and uphaul and downhaul lanyards, ropes and shockcord are permitted.
- (c) The method of fixing the tiller to the **rudder** is optional. The tiller may be incorporated in the **rudder** head or stock. A pin or other fitting to secure the tiller to the **rudder** is permitted.
- (d) The method of fixing the tiller extension to the tiller is optional, and a bolt, rubber link, universal joint or other fitting or device and appropriate fastenings may be used for this purpose

E.4.3 **DIMENSIONS** (see also C.8.2.3)

E.4.3.1 When the tip of the **rudder** blade is in its lowest position that part of it which lies below the straight line extension of the top of the keel from the aft transom shall:

- (a) Fit within the profile PQRS shown on measurement plan No.3, and
- (b) At no point shall be more than 5mm from the straight lines P-Q and R-S or the semi-circle Q-R.

And no part of the **rudder** blade shall extend beyond the straight line extensions of P-Q or R-S.

E.4.3.2 The **rudder** blade shall comply with the following:

	<u>Minimum</u>	<u>Maximum</u>
Total thickness of <b>rudder</b> blade .....	12mm	14mm
The bevel of the edges from the edge of <b>rudder</b> blade .....	-	29mm
Thickness variation of the <b>rudder</b> blade (except within the bevelled parts) .....	-	1mm
The radius of the leading and trailing edges .....	1.5mm	-

E.4.4 **WEIGHT**

	minimum	maximum
Weight of <b>rudder</b> , stock, tiller and extension .....	3 kg	.....

Any **correctors** needed shall be of lead and permanently secured aft of the **rudder** pintles.

## Section F – Rig

### F.1 PARTS

#### F.1.1 MANDATORY

- (a) **Mast**
- (b) **Boom**
- (c) Standing **rigging**
- (d) Running **rigging**

#### F.1.2 OPTIONAL

- (a) **Spinnaker pole**

### F.2 GENERAL

#### F.2.1 RULES

- (a) **Spars** which (i) have been certified by way of a Class label and measurer's signature under any earlier version of these rules and (ii) have not been subsequently altered or repaired otherwise than by way of routine maintenance such as painting and polishing and the repair of minor chips and abrasions, shall comply with the **class rules** in force at the date of such **certification**.
- (b) All other **spars** shall comply with these **class rules**.

#### F.2.2 DEFINITIONS

- (a) MAST DATUM POINT

The **mast datum point** is the lowest point of the **spar** excluding the tenon.

#### F.2.3 MANUFACTURER

- (a) The manufacturers of **spars** are optional.

### F.3 MAST

#### F.3.1 MATERIALS

- (a) The **spar** shall be of wood or aluminium alloy.
- (b) The material of the sail track is optional.

#### F.3.2 CONSTRUCTION

- (a) The **spar** extrusion shall include a fixed sail groove or track which may or may not be integral with the **spar**.
- (b) The **spar** shall include a **mast** tenon which in the case of an aluminium alloy mast shall be incorporated in an end plug or fitting. The lateral and fore and aft bearing surfaces of the **mast** tenon socket shall lie between the outside of a 28mm X 28mm horizontal square and the inside of a concentric 30mm X 30mm horizontal square.
- (c) If made of aluminium alloy the mast shall not be tapered and shall not be sleeved or reinforced except where locally required for the purpose of attaching fittings, and then within a maximum of 30mm from the fitting attachment point concerned.
- (d) If made of wood, the section may be hollowed and the section may be tapered from 3045mm above the **mast datum point** to a minimum diameter of 38mm at the **upper point**.
- (e) A **mast upper limit mark**, a **mast lower limit** mark and a mid band shall be permanently marked on the **spar**.

#### F.3.3 FITTINGS

- (a) MANDATORY

- (1) The main, headsail and spinnaker **halyards** shall be carried down the outside of the **mast**, for which purpose the sail groove or track is treated as part of the inside of the mast.
- (2) Shroud and forestay tangs or attachment holes, fittings or points.
- (3) Gooseneck, fixed so that the top edge of the **boom** cannot be below the **lower point**.

- (4) Blocks, sheaves and sheave boxes or fittings for main and headsail **halyards**, but not so as to permit any purchases on the **halyards**, which can only be achieved by loops in the **halyards**.
  - (5) In the case of an aluminium alloy **mast**: a plastic, alloy or wooden mast end plug or fitting incorporating a tenon.
- (b) OPTIONAL
- (1) Clip or bracket for flag, burgee, or mechanical wind indicator.
  - (2) Eye and cleat for burgee **halyard**.
  - (3) Compass bracket.
  - (4) **Mainsail** Cunningham block, fairlead and cleat.
  - (5) Spinnaker **halyard** fairlead on the front of the **mast**
  - (6) One or two **spinnaker pole** fittings
  - (7) Blocks, cleats and fairleads for the operation of the spinnaker pole up haul/down haul system
  - (8) A stop may be fitted to the **mast** to prevent the **mainsail** from being pulled beyond the **upper point**.
  - (9) Plastic or alloy sail feeder

F.3.4 DIMENSIONS

	minimum	maximum
<b>Mast spar</b> cross sectional dimension.....	43 mm	
<b>Mast spar</b> cross sectional dimension for		
wooden mast at <b>Upper point</b> .....	38 mm	
Start of taper on wooden mast from <b>mast datum point</b> .....	3045 mm	
<b>Mast limit mark</b> and band <b>width</b> .....	10 mm	
<b>Lower point height</b> above <b>mast datum point</b> .....	489 mm	
<b>Upper point height</b> above <b>mast datum point</b> .....	4629 mm	
Mid band height. Lower edge above <b>mast datum point</b> .....	3049 mm	3099 mm
<b>Forestay height</b> below mid band.....		75 mm
<b>Shroud height</b> below mid band.....		75 mm
Centre of sheave of foresail <b>halyard</b> block below mid band .....		250mm
<b>Spinnaker pole fitting:</b>		
<b>height</b> above <b>mast datum</b> .....		667 mm
<b>projection</b> .....		35 mm
<b>Spinnaker hoist height</b> above <b>mast datum</b> .....		3156 mm
<b>Spinnaker halyard</b> fairlead projection .....		25 mm
<b>Mast Datum Point</b> to <b>Heel Point</b> .....		13 mm
Length of tenon .....	28mm	30mm
Width of tenon .....	28mm	30mm
Distance from <b>mast datum point</b> as defined in F.2.2 to centre of gravity in condition as described in F.3.5 .....		2200 mm

F.3.5 WEIGHT

	minimum	maximum
Mast weight including fixed fittings but excluding standing and running rigging and shroud lanyards.....		4 kg

F.4 BOOM

F.4.1 MATERIALS

- (a) The **spar** shall be of wood or aluminium alloy.
- (b) The material of the sail track is optional.

F.4.2 CONSTRUCTION

- (a) The **spar** extrusion shall include a fixed sail groove or track which may or may not be integral with the **spar**.
- (b) A **boom outer limit mark** shall be permanently marked on the **spar**.



F.4.3 FITTINGS

(a) MANDATORY

- (1) One or two single sheave mainsheet blocks with attachments
- (2) Kicking strap fitting
- (3) If centre mainsheet system is used: one or more soft loops.
- (4) Fitting and/or hole for attachment of **boom** to gooseneck.

(b) OPTIONAL

- (1) **Mainsail** outhaul blocks, fairleads, and attachment and other fittings and cleat.
- (2) Fitting for the attachment of the **tack** of the **mainsail**. This fitting may be separate from or incorporated with the fitting for attaching the **boom** to the gooseneck.
- (3) **Spinnaker pole** stowage fittings
- (4) A maximum of two clips or loops on either side of the boom to store the **spinnaker pole**. If stored using those clips or loops then the pole shall stow close to the **boom** and the end furthest away from the **mast** shall be contained or covered in a manner that there is no possibility of it catching the clothing of either **crew**.
- (5) A stop to prevent the **mainsail** from being pulled beyond the **outer point**.

F.4.4 DIMENSIONS

	minimum	maximum
<b>Boom spar cross section</b> including track .....	37 mm	65 mm
<b>Limit mark width</b> .....	10 mm	
<b>Outer point distance</b> .....		1894 mm
Single block B for centre mainsheet from aft side of the <b>mast</b> .....	680 mm	800 mm
Soft loop(s) for centre mainsheet aft of block B above.....	300 mm	400 mm
Distance from forward end of <b>boom</b> to		
Kicking strap fitting .....	457 mm	507 mm

F.4.5 WEIGHTS

	minimum	maximum
<b>Boom weight</b> .....	1.7 kg	

F.5 SPINNAKER POLE

F.5.1 MANUFACTURER

- (a) Manufacturer is optional.

F.5.2 MATERIALS

- (a) The **spar** shall be of aluminium alloy or wood.

F.5.3 CONSTRUCTION

- (a) The section is optional

F.5.4 FITTINGS

- (a) There shall be only one hook or piston end fitting (which may be spring loaded) at each end.
- (b) The hooks or piston end fittings may be connected by lanyards and/or shockcord.
- (c) Optional trips, levers or sliders are permitted on the pole for assisting with the operation of the lanyard(s) and shockcord.
- (d) Fittings for the attachment of up haul and down haul are optional.

F.5.5 DIMENSIONS

	minimum	maximum
<b>Spinnaker pole</b> length .....		1219 mm

F.6 STANDING RIGGING

F.6.1 MATERIALS

- (a) The standing **rigging** shall be stranded non-faired wire of stainless steel or galvanised plough steel.

- F.6.2 CONSTRUCTION
- (a) MANDATORY
- (1) One **forestay**.
  - (2) One pair of **shrouds**.
- (b) OPTIONAL
- (1) Wire strop for attaching the foresail **halyard** block to the **mast**. The wire strop may be attached directly to the **mast** or it may be swaged or spliced to the **forestay** or the **forestay** may be swaged or spliced to the strop.

- F.6.3 FITTINGS
- (a) MANDATORY
- (1) **Forestay** lanyard
- (b) OPTIONAL
- (1) Eyes, swages, end terminals and end fittings for **forestay**, **shrouds** and foresail **halyard** block strop.
  - (2) **Shroud** lanyards or **shroud** adjusting plates incorporating rows of holes and clevis pins.
  - (3) Shockcord to take up slack in **forestay**.

F.6.4 DIMENSIONS

	minimum	maximum
<b>Forestay</b> diameter .....	2.5 mm	
<b>Shroud</b> diameter .....	2.5 mm	
Wire strop for headsail <b>halyard</b> block .....	2.5 mm	
Distance between bottom ends of <b>forestay</b> and <b>shrouds</b> and attachment points on <b>hull</b> .....		200mm

## F.7 RUNNING RIGGING

- F.7.1 MATERIALS
- (a) The running rigging shall be of rope save that the standing part or parts of the kicking strap may be of wire.

- F.7.2 CONSTRUCTION
- (a) MANDATORY
- (1) Mainsail **halyard**
  - (2) Mainsail sheet
  - (3) Kicking strap
  - (4) Headsail **halyard**
  - (5) Headsail sheet(s)
- (b) OPTIONAL
- (1) Mainsail Cunningham line
  - (2) Mainsail outhaul lines.
  - (3) Headsail Cunningham line
  - (4) Spinnaker **halyard**
  - (5) Spinnaker sheet(s)
  - (6) Spinnaker pole lift and downhaul lines

- F.7.3 FITTINGS
- (a) OPTIONAL
- (1) Blocks, fairleads and cleat for kicking strap system.
  - (2) Shackles, swivel links, clips, plastic bobbles or stoppers.
  - (2) Metal or plastic thimbles or hard eyes for reinforcing main and headsail **halyards** if looped for additional purchase.

- F.7.4 DIMENSIONS
- (a) Tapered **halyards** and sheets are not permitted except that where a centre mainsheet is used the two legs of the mainsail sheet which attach to the transom points may have different diameters from the remainder of the mainsheet, and where the legs join the remainder of the

mainsheet, the mainsheet may be tapered for a maximum length of 600mm. Other ropes and lines may be tapered.

## Section G – Sails

### G.1 PARTS

#### G.1.1 MANDATORY

- (a) Mainsail
- (b) Headsail

#### G.1.2 OPTIONAL

- (a) Spinnaker

### G.2 GENERAL

#### G.2.1 RULES

- (a) **Sails** shall comply with the **class rules** in force at the time of their **certification**, except that **sails** used in an International Championship shall comply with current **class rules**.

#### G.2.2 CERTIFICATION

- (a) All **sails** shall be **certified** by either a measurer or an **In-House Official Measurer**
- (b) **Sails certified** after 1<sup>st</sup> December 2010 shall be **certified** by the measurer applying the **certification mark** on **mainsails** and **headsails** in the **tack** and spinnakers in the **head**.
- (c) For **sails certified** after 1<sup>st</sup> December 2010 the **certification mark** shall include at least (i) the measurer's signature, (ii) the measurer's name in print or block capitals, (iii) the name or initials of the authority by whom the measurer is recognised, and (iv) the date of **certification**. In the case of an **In-House Official Measurer** the **certification** mark shall be made according to the In-house Certification Programme guidelines.
- (d) Conformity with Section C rules is not required for **certification control** and therefore if parts controlled only by Section C are not present at the time of **certification control** they need not be checked; however if parts including but not limited to, class insignia, national letters, and sail numbers are present, they shall be checked.

#### G.2.3 ROYALTY LABEL OR BUTTON

- (a) **Sails certified** after 1<sup>st</sup> March 1987 shall have an official International Cadet class label or button fixed to the **mainsail** and **headsail** near the **tack** and the **spinnaker** near the **head** (**Spinnakers certified** pre March 2002 may have the label near the **clew**) before the **sail** is **certified**.
- (b) Sail labels or buttons shall not be transferred from one **sail** to another.

#### G.2.4 MODIFICATIONS, MAINTENANCE AND REPAIR

- (a) **Sails** shall not be altered in any way except as permitted by these **class rules**.

#### G.2.5 SAILMAKER

- (a) No licence is required.

### G.3 MAINSAIL

#### G.3.1 MATERIALS

- (a) The **body of the sail** shall be made of **woven ply**.
- (b) **Ply** fibres shall consist of polyester.
- (c) **Stiffening** shall consist of:
  - (1) Mainsail headboard of plastic or aluminium
  - (2) Battens of wood or GRP.
- (d) **Sail reinforcement** shall consist of **woven ply**.

#### G.3.2 CONSTRUCTION

- (a) The construction shall be: **soft sail, single ply sail**.
- (b) The **sail** shall have 3 **batten pockets** in the **leech**. The pockets shall be placed on the leech so that the centres of the pockets at the leech are at the **quarter, half** and **three quarter leech points** plus or minus 30mm.

- (c) The following are permitted: Stitching, glues, **tabling, seams, tucks, darts**, seizing, bolt ropes/shock cord, corner eyes or cringles, headboard with fixings, Cunningham eye, cringle or block, **batten pocket patches, batten pocket elastic, batten pocket end caps, flutter patches, mast and boom slides**, one line of reef points (which may consist of lines sewn onto the sail or of eyes or cringles), tell tales, sail shape indicator stripes, flag or burgee clip attached to headboard, **mast and boom slides**, shackle, pin, lanyard or strap for attaching **tack to boom or mast**, one **window** (which need not be of **woven ply**), sailmaker's marks and items as permitted or prescribed by other applicable *rules*.

### G.3.3

#### DIMENSIONS

	minimum	maximum
<b>Leech length</b> .....	4400 mm	4471 mm
<b>Quarter width</b> .....		1560 mm
<b>Half width</b> .....		1130 mm
<b>Three-quarter width</b> .....		635 mm
<b>Top width</b> .....		115 mm
<b>Primary reinforcement:</b>		
from <b>sail corner measurement points</b> .....		275 mm
at an adjustment point .....		275mm
at a reefing point adjacent to the <b>luff or leech</b> .....		275mm
at any other reefing point .....		100mm
<b>Secondary reinforcement:</b>		
from <b>sail corner measurement points</b> .....		825 mm
for <b>flutter patches</b> .....		120 mm
for <b>batten pocket patches</b> .....		200 mm
for reefing points.....		275mm
Distance from <b>clew point</b> to <b>foot</b> bolt rope .....		100 mm
Distance from <b>tack point</b> to <b>foot</b> bolt rope .....		350 mm
<b>Window length</b> .....		400 mm
<b>Window height</b> .....		200 mm
<b>Tabling width</b> .....		40 mm
<b>Seam width</b> .....		30 mm
<b>Batten length</b> .....		457 mm
<b>Batten width</b> .....		38 mm
Height of reefing points above straight lione joining <b>clew point</b> to <b>tack point</b> ...	560 mm	610 mm
Class Insignia, National Letters and Sail Numbers:		
Height .....	300 mm	
Width .....	200 mm	
Thickness .....	45 mm	
Space between characters, numerals and from edge of sail.....		45mm

## G.4 HEADSAIL

### G.4.1 MATERIALS

- (a) The **body of the sail** shall be made of **woven ply**.  
 (b) **Ply** fibres shall consist of polyester.  
 (c) **Sail reinforcement** shall consist of **woven ply**.

### G.4.2 CONSTRUCTION

- (a) The construction shall be: **soft sail, single ply sail**.  
 (b) The headsail shall have a luff wire at the **luff** which the sail shall pass around. Hanks or clips for attaching the headsail to the **forestay** are optional.  
 (c) The following are permitted: Stitching, glues, **tabling, seams, tucks, darts**, seizing, corner eyes or cringles, **flutter patches**, tell tales, sail shape indicator stripes, **luff hanks or clips**, lanyard, shackle or clevis pin for attaching **tack** to bow fitting, fairlead or fairleading block and cleat for headsail Cunningham, one **window** (which need not be of **woven ply**), sailmaker's marks, and items as permitted or prescribed by other applicable *rules*.

- (d) A non elastic line may be inserted in the foot of the headsail.
- (e) A headsail Cunningham eye or cringle may be fitted.

G.4.3 DIMENSIONS

	minimum	maximum
<b>Luff length</b> .....	2650 mm	2743 mm
<b>Leech length</b> .....		2362 mm
<b>Foot length</b> .....		1067 mm
<b>Foot median</b> .....		2560 mm
<b>Top width</b> .....		30 mm
<b>Foot irregularity</b> .....		45 mm
<b>Primary reinforcement</b> .....		230 mm
<b>Secondary reinforcement:</b>		
from <b>sail corner measurement points</b> .....		690 mm
for <b>flutter patches</b> .....		120 mm
<b>Tabling width</b> .....		40 mm
<b>Seam width</b> .....		30 mm
<b>Window length</b> .....		400 mm
<b>Window height</b> .....		200 mm

G.5 SPINNAKER

G.5.2 MATERIALS

- (a) The **body of the sail** shall be made of **woven ply**.
- (b) **Ply** fibres shall consist of nylon or polyester.
- (c) **Sail reinforcement** shall consist of **woven ply**.

G.5.3 CONSTRUCTION

- (a) The construction shall be: **soft sail, single ply sail**.
- (b) The **body of the sail** shall consist of **woven ply** throughout. Reinforcement shall consist of **woven ply**.
- (c) The following are permitted: Stitching, glues, **tabling, seams, tucks, darts**, seizing, corner eyes or cringles, tell tales and items as permitted or prescribed by other applicable *rules*.

G.5.4 DIMENSIONS

	minimum	maximum
<b>Leech lengths</b> .....	2850 mm	3048 mm
<b>Foot length</b> .....		1825 mm
<b>Foot Median</b> .....		3048 mm
Difference between <b>clew diagonals</b> .....		50 mm
<b>Quarter width</b> .....		1925 mm
<b>Half width</b> .....		1710 mm
<b>Three-quarter width</b> .....		1020 mm
<b>Tabling width</b> .....		30 mm
<b>Seam width</b> .....		30 mm
<b>Primary reinforcement</b> .....		240 mm
<b>Secondary reinforcement:</b>		
from <b>sail corner measurement points</b> .....		720 mm
for <b>flutter patches</b> .....		120 mm

# PART III – APPENDICES

---

The rules in Part III are **closed class rules**. Measurement shall be carried out in accordance with the ERS except where varied in this Part.

## Section H

### H.1 WOODEN BOAT SUPPLEMENT

H.1.1 Mark II and Mark III hulls shall include the following parts:

- H.1.1.1 Two hull bottom panels.
- H.1.1.2 Two hull side panels.
- H.1.1.3 One keel.
- H.1.1.4 One skeg.
- H.1.1.5 One hog.
- H.1.1.6 One aft transom.
- H.1.1.7 One fore transom.
- H.1.1.8 One thwart.
- H.1.1.9 One fore and one aft bulkhead.
- H.1.1.10 One **daggerboard** case.
- H.1.1.11 Decks.
- H.1.1.12 Inwales.
- H.1.1.13 Carlines.
- H.1.1.14 **Daggerboard** case bed logs which shall not exceed 30mm in width or 25mm in height.
- H.1.1.15 **Daggerboard** case packing pieces which may be extended aft to support the thwart and forward to support the daggerboard case capping (if used).
- H.1.1.16 Rubbing strakes or beads.
- H.1.1.17 Such other parts as are mandatory under the **class rules**.

H.1.2 The **daggerboard** case shall comply with **class rule** D.5. Its sides shall be made out of sheet timber material except that the faces inside the case may be lined with sheet material other than timber (such as "Formica") not more than 2mm thick. The daggerboard case may have a capping in conformity with H.1.3.5 below.

H.1.3 Mark II and Mark III hulls may include the following parts:

- H.1.3.1 A kingpost.
- H.1.3.2 A king plank and an equivalent plank under the stern deck.
- H.1.3.3 Deck beams.
- H.1.3.4 Chine and deck stringers.
- H.1.3.5 **Daggerboard** case capping which may be joined to the thwart and may extend forward and be joined to forward bulkhead and/or the kingpost, but which shall not exceed 150mm in overall width (measured from the port side of the port capping to the starboard side of the starboard capping) and shall not exceed 30mm in depth.
- H.1.3.6 Floor battens.
- H.1.3.7 Knees, pads, supports, spacers, chocks, and packing pieces.
- H.1.3.8 Any other part or parts which are optional under the **class rules**.
- H.1.3.9 Beads or lines of glue or epoxy (with or without fillers) to assist in the joining of parts.
- H.1.3.10 On a Mark II **hull** non-wooden material may be used as part of the side deck or carline construction within 25mm of the inboard edges of the flat upper surface of the side decks (as defined in D.2.1).
- H.1.3.11 Non-wooden, non-metallic material may be used within 10mm of the fore and aft edges of the thwart.

H.1.4 Where an item is listed in this Supplement and is also referred to in Part I or Part II of the **class rules**, it must comply with the requirements of Part I or II of the **class rules**.

H.1.5 Where anything is required by Part I or II of the **class rules**, whether or not it is mentioned in this Supplement, it is required and Parts I and II of the **class rules** must be complied with in all respects.

H.1.6 Except for those items (or parts of them) in respect of which dimensions, shapes, limited rounding or radiuses or other matters are specified above or in Part I or II of the **class rules** (in respect of which those

specifications shall apply) any of the items listed in this Supplement may be of any dimension or shape and may be tapered, chamfered or rounded.

H.1.7 The use of any of the above items in such a way as to result in a departure from the intended nature and construction of the boats is not permitted. Any question raised under this rule shall be decided by the Technical Committee of the ICA, whose decision shall be final.

## H.2 Measurement Plan No 1 (Illustrative Only)

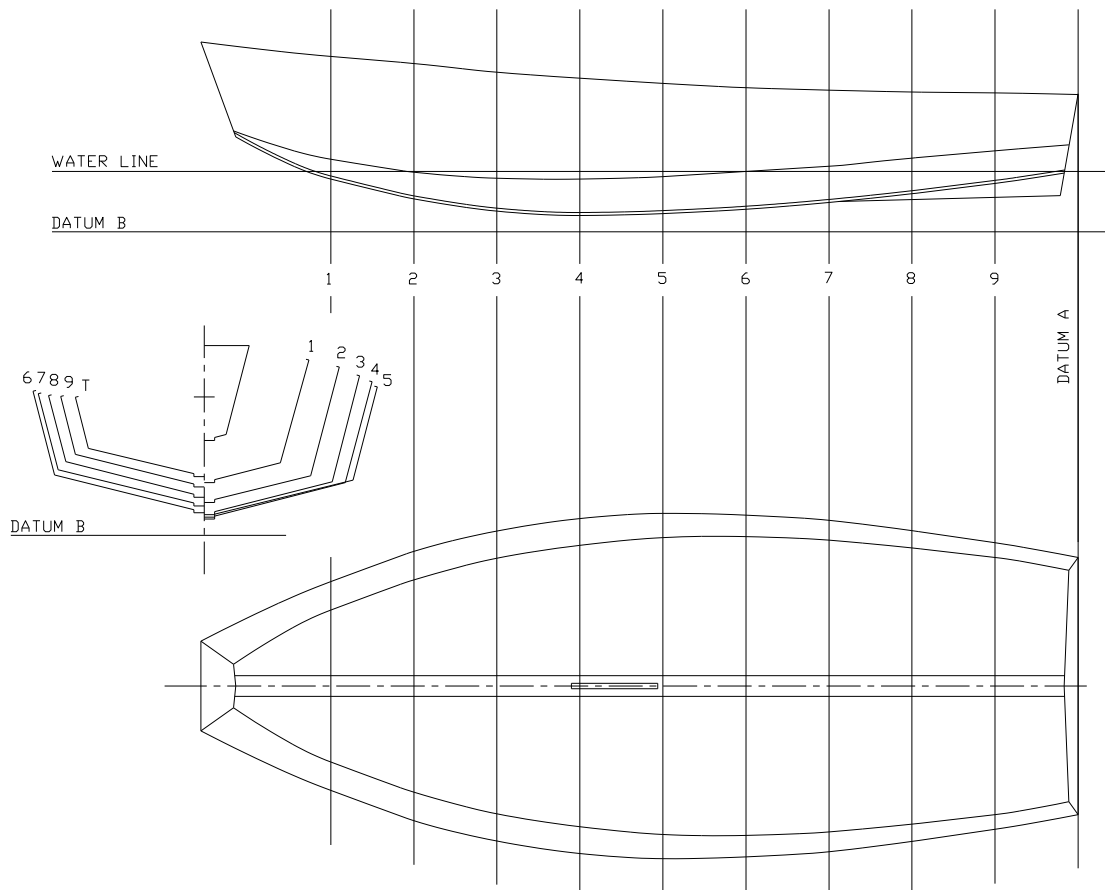



### H.3 Measurement Plan No 2

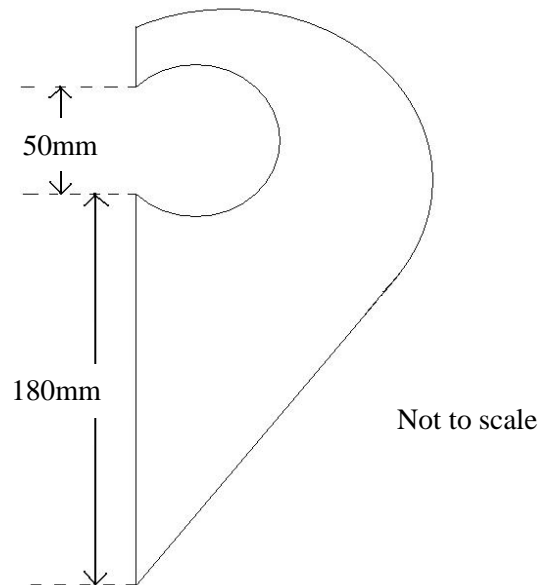
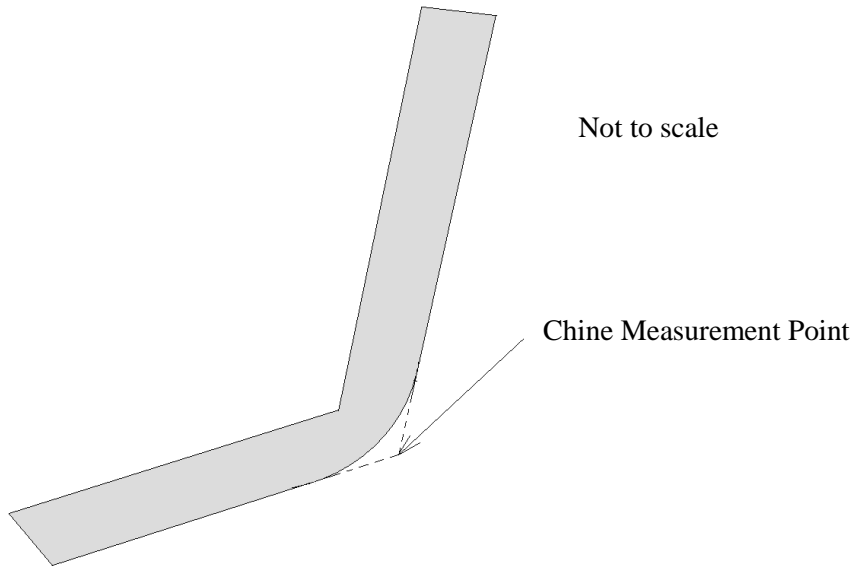

Illustrative drawing of template  
for finding Datum point "A"  
and Datum Line "C"

## H.4 Measurement Plan No 3

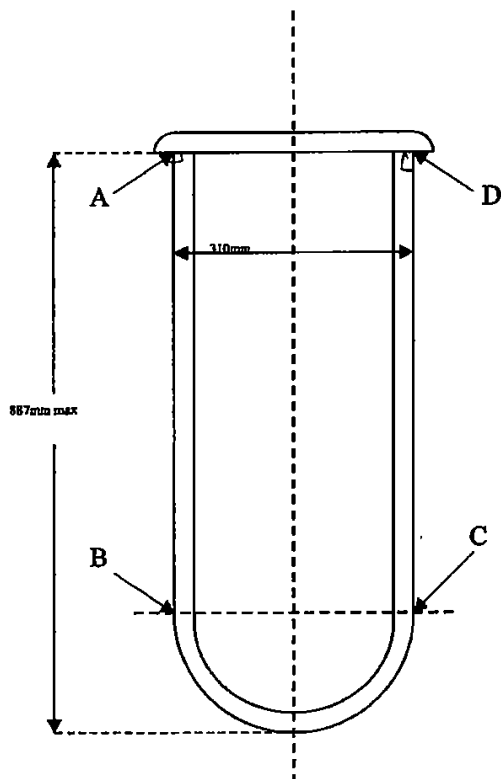

Daggerboard

1. Lines A-B and D-C are parallel straight lines 310mm apart.
2. The curved line B-C is a semi-circle of radius 155mm.
3. The angles BAD and ADC shall be  $90^\circ \pm 2^\circ$ .

Not to scale

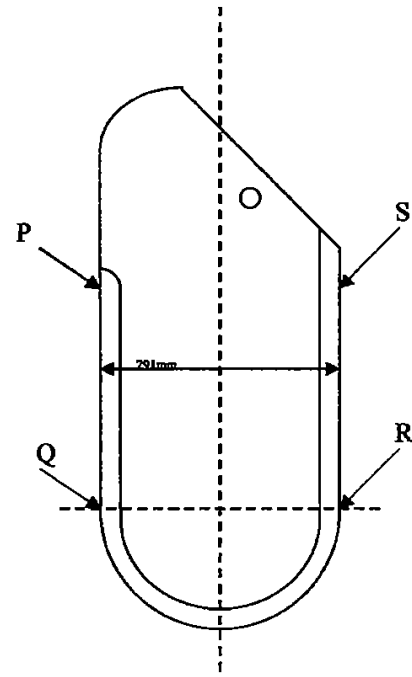

Rudder Blade

Points P and S are the points on the leading and trailing edges of the blade where those edges intersect the straight line extension of the top of the keel from the transom when the tip of the rudder blade is in its lowest position.

1. Lines P-Q and S-R are parallel straight lines 291mm apart.
2. the curved line Q-R is a semi-circle of radius 145.5mm.

### Optional Lifting Handle:

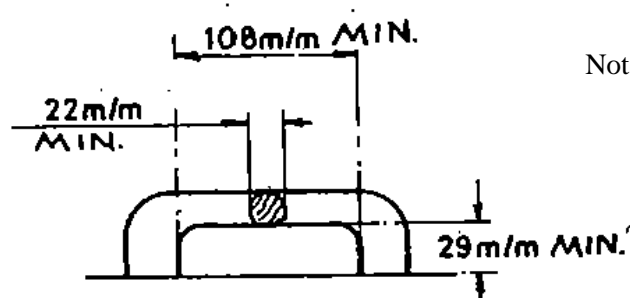

Not to scale

## H.5 Measurement Plan No 4

Illustrative Only

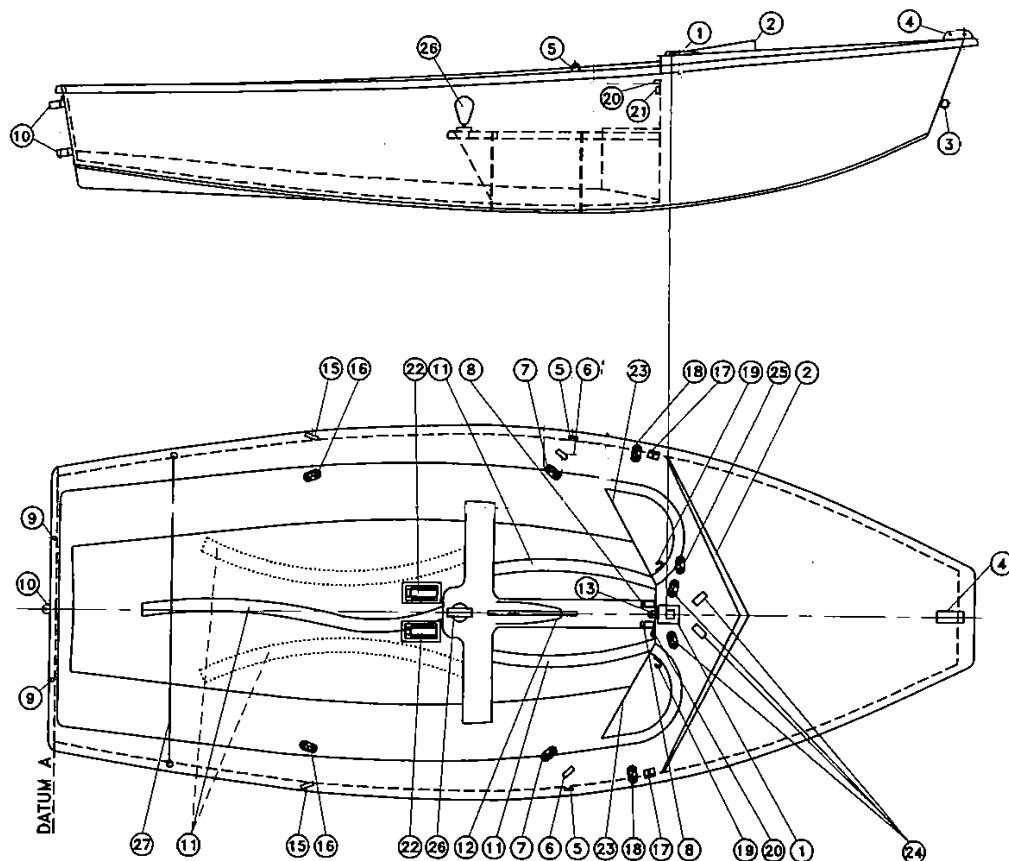

- |                                      |   |   |
|--------------------------------------|---|---|
| 1 Mast step block / protective plate | 11 Toe strap                                  | 21 Spinnaker halyard cam cleat                    |
| 2 Spray guard                        | 12 Shock cord                                 | 22 Self bailer                                    |
| 3 Towing fitting                     | 13 Kicking strap eye plate                    | 23 Open compartment for spinnaker and loose gear  |
| 4 Bow plate                          | 14 Mainsail Cunningham block etc. (not shown) | 24 Blocks and fairleads for spinnaker up/downhaul |
| 5 Hull shroud plate or U bolt        | 15 Spinnaker sheet fairlead                   | 25 Cleat for headsail Cunningham                  |
| 6 Headsail fairleads                 | 16 Spinnaker sheet cam cleat                  | 26 Main sheet block or ratchet block              |
| 7 Headsail sheet cam cleat           | 17 Open spinnaker sheet fairlead              | 27 Shock cord keeping main sheet inside boat      |
| 8 Mainsail / headsail halyard cleat  | 18 Spinnaker sheet cleat                      | 28 ---  |
| 9 Mainsail sheet attachment point    | 19 Spinnaker halyard lancing hook             | 29 ---  |
| 10 Transom gudgeon or pintle         | 20 Spinnaker halyard fairlead                 | 30 ---  |

# Measurement Plan No.5

## INTERNATIONAL CADET

MARK 3 (WOOD)  
DIAGRAM A - DECK STRUCTURE  
SECTION 5 (1524 mm FROM DATUM A)

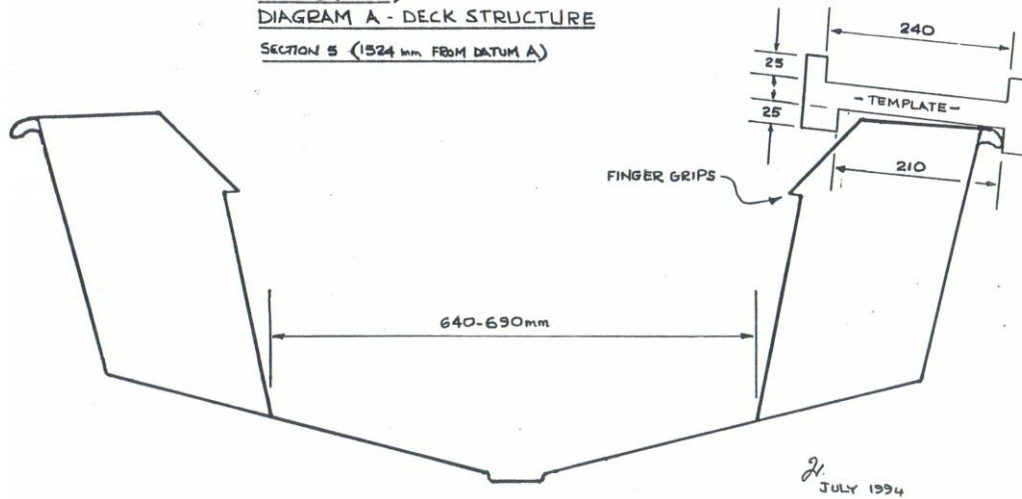

---

## INTERNATIONAL CADET

MARK 3 (WOOD)  
DIAGRAM B  
DECK STRUCTURE

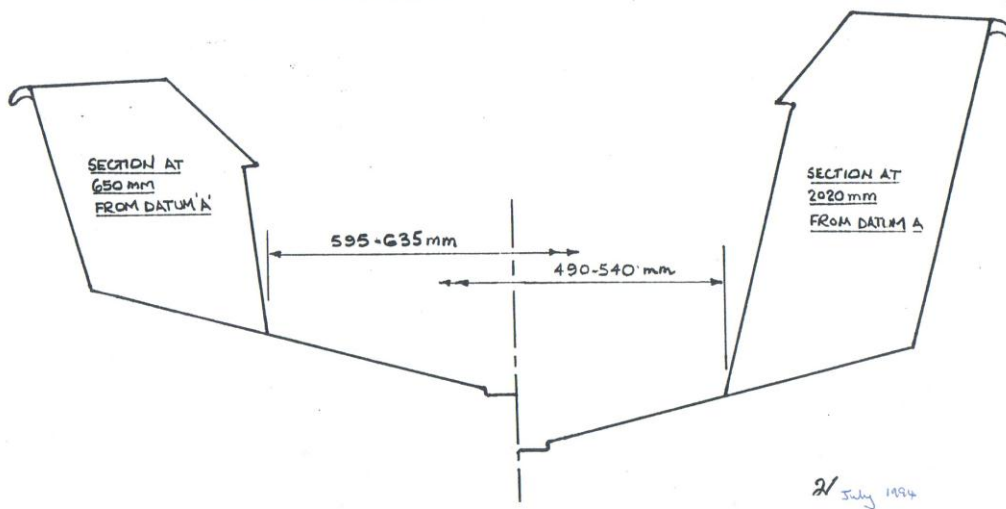

# Measurement Plan No.6

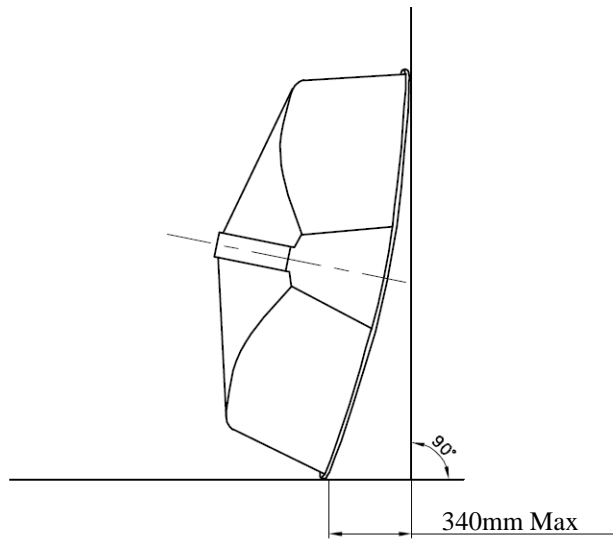
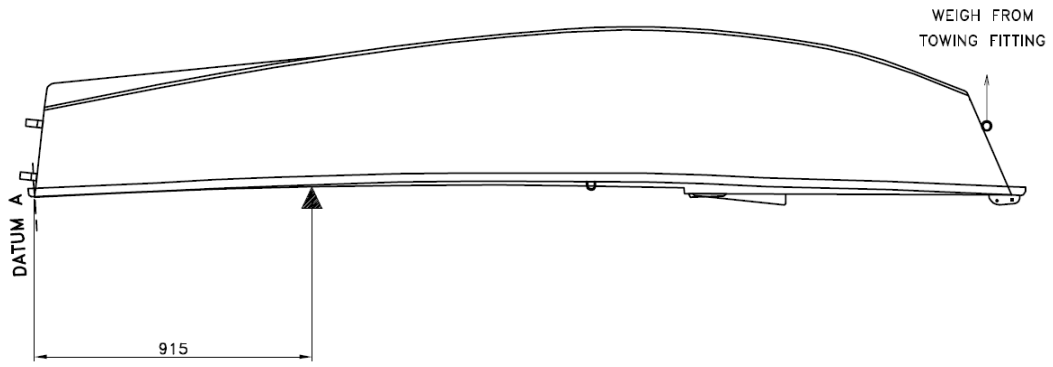

## H.8 Buoyancy Tests

- H.8.1 All boats shall be tested for buoyancy with corrector weights, if any, in place. For the test (except for the initial air test for Mark IVs), the boat, with deck and fixed fittings, shall be stripped of all loose gear, including sails, booms, rudder, tiller and daggerboard, but leaving the mast stepped and shrouds and forestay set up. 125 kg of crew weight shall be placed aboard the floating boat and the boat flooded such that the water is above the level of the top of the daggerboard case. After 15 minutes in this condition the boat shall be capsized for one minute to port and one minute to starboard, then the boat shall be drained. Any water in the watertight compartments shall be measured. This shall not exceed 2 litres in total or 1 litre in any individual compartment.
- H.8.2 A measurer (which for this purpose shall include a Squadron Captain) may place a buoyancy endorsement on a certificate when he has successfully carried out the test described above and has inspected all buoyancy apparatus, bulkheads, and inspection and drainage holes and their covers or stoppers, and has satisfied himself that all are in sound condition.
- H.8.3 The buoyancy apparatus of a new Mark IV hull shall (before a certificate is issued in respect of it) satisfy the following air test ("the initial air test"):
- (a) On the tank being tested only, inspection and drain holes shall be closed normally using only the boat's covers, stoppers and fastenings except where tubes to a pressure/vacuum source and gauge are connected. All other inspection and drain holes shall be open.
  - (b) Each compartment shall be tested independently under both pressure and vacuum. In each case a differential pressure of 125mm on a water gauge shall be produced.
  - (c) After isolating the compartment from the pressure/vacuum source the pressure differential shall not reduce from 125mm to 50mm in less than 30 seconds.

## H.9 Examples relating to Minor Repairs

H.9.1 The following are minor repairs:

- (1) The replacement of the bow transom, provided that the shape of the **hull** is not altered and no advantage is obtained

H.9.2 The following are not minor repairs:

- (1) The replacement of more than 50% of the material of an original **hull** panel. Or
- (2) The replacement of more than 50% of the material of the side decks or of more than 50% of the fore deck or of more than 50% of the stern deck. Or
- (3) The replacement of more than 50% of the material of the original aft transom.

And so that if a panel, deck or aft transom is removed or replaced in stages, such removal or replacement will be deemed to become a replacement within (1), (2) or (3) above at the time when more than 50% of the original material has been removed, even if the original material is or has been put back into the **hull** either before further material is removed or otherwise.